

HP Archive

This vintage Hewlett Packard document was
preserved and distributed by

[www. hparchive.com](http://www.hparchive.com)

Please visit us on the web !

On-line curator: Tony Gerbic



OPERATING AND SERVICE MANUAL

MODEL 141A OSCILLOSCOPE

SERIALS PREFIXED: 547-

Copyright HEWLETT-PACKARD COMPANY/COLORADO SPRINGS DIVISION 1965
1900 GARDEN OF THE GODS ROAD, COLORADO SPRINGS, COLORADO, U. S. A.

TABLE OF CONTENTS

Section	Page	Section	Page
I GENERAL INFORMATION	1-1	4-26. Storage CRT	4-3
1-1. Description	1-1	4-33. Pulse Circuit	4-4
1-6. Cathode Ray Tube	1-1	4-40. Trace Align	4-4
1-8. CRT Warranty	1-1	4-42. Plug-In Kit Fabrication	4-5
1-10. Associated Equipment	1-1	V MAINTENANCE	5-1
1-12. Manual Identification	1-2	5-1. Introduction	5-1
1-14. Scope of Manual	1-2	5-3. Performance Check	5-1
II INSTALLATION	2-1	5-4. CRT Controls	5-1
2-1. Initial Inspection	2-1	5-5. Calibration	5-1
2-4. Preparation for Use	2-1	5-6. Adjustments	5-2
2-5. Power Requirements	2-1	5-11. Adjustments of Low-Voltage Supply	5-2
2-9. Instrument Mounting	2-1	5-13. Adjustments of High-Voltage Supply	5-2
2-12. Instrument Cooling	2-1	5-14. Intensity Limit Adjustment	5-2
2-15. Claims	2-1	5-15. Astigmatism Adjustment	5-2
2-17. Repackaging for Shipment	2-2	5-16. Geometry Adjustment	5-2
III OPERATION	3-1	5-17. Calibration Adjustment	5-2
3-1. Introduction	3-1	5-18. Pulse Circuit Adjustment	5-2
3-3. Front Panel Components	3-1	5-23. Troubleshooting	5-6
3-8. Rear Panel Components	3-1	5-24. Low-Voltage Supply	5-6
3-11. Plug-In Units	3-1	5-31. High-Voltage Supply	5-6
3-14. Operating Considerations	3-1	5-36. Pulse Circuit	5-8
3-15. Definitions	3-1	5-40. Periodic Maintenance	5-8
3-17. Control Functions	3-3	5-41. Electrical Maintenance	5-8
3-21. Operating Tips	3-3	5-43. Mechanical Maintenance	5-8
3-23. Single-Shot Operation	3-3	5-45. Instrument Repair	5-8
IV PRINCIPLES OF OPERATION	4-1	5-48. Major Component Repair	5-8
4-1. Overall Functional Description	4-1	5-52. Servicing Circuit Boards	5-9
4-7. Circuit Description	4-1	VI REPLACEABLE PARTS	6-1
4-8. Low-Voltage Supply	4-1	6-1. Introduction	6-1
4-16. Calibration	4-2	6-4. Ordering Information	6-1
4-20. High-Voltage Supply	4-2		

LIST OF ILLUSTRATIONS

Number	Title	Page	Number	Title	Page
1-1.	Model 141A Oscilloscope with Model 1400A Amplifier and Model 1402A Plug-Ins	1-1	4-4.	Pulse Circuit Block Diagram	4-4
2-1.	Rack Mounting Procedure	2-2	5-1.	Component Locations, Bottom View	5-3
3-1.	Model 141A Controls	3-2	5-2.	Component Locations, Top View	5-5
3-2.	Background Illumination	3-4	5-3.	High-Voltage Deck Removal	5-9
3-3.	Variable Persistence	3-4	5-4.	High-Voltage Deck Board	5-10
3-4.	Single-Shot Trace Bloom	3-4	5-5.	Component Identification, Horizontal Driver Board	5-13
3-5.	Single-Shot, No Bloom	3-4	5-6.	Component Identification, High-Voltage Board	5-13
3-6.	Fade Positive	3-5	5-7.	Low-Voltage Schematic Diagram	5-14
3-7.	Single-Shot, Fast Sweep	3-5	5-8.	High-Voltage Schematic Diagram	5-15
3-8.	Single-Shot, Fade Positive	3-5	5-9.	Component Identification, Low-Voltage Board	5-15
3-9.	Storage Mesh Imperfections	3-5	5-10.	Waveforms	5-16
4-1.	Model 141A Block Diagram	4-1	5-11.	Pulse Circuit Schematic Diagram	5-17
4-2.	Regulated Power Supply Block Diagram	4-2	5-12.	Component Identification, Pulse Circuit	5-18
4-3.	High-Voltage Power Supply Block Diagram	4-3	5-13.	Plug-In Jack Connection	5-18
			6-1.	Cabinet Parts, Exploded View	6-2

LIST OF TABLES

Number	Title	Page	Number	Title	Page
1-1.	Specifications	1-0	5-4.	Troubleshooting the High-Voltage Supply, No Voltage	5-6
1-2.	Plug-Ins for Model 141A Oscilloscope	1-2	5-5.	Troubleshooting the Low-Voltage Supply	5-7
2-1.	Shipping Carton Test Strengths	2-2	5-6.	Troubleshooting High-Voltage Supply, Incorrect Voltage	5-8
4-1.	Current Capability	4-5	5-7.	Schematic Diagram Notes	5-11
5-1.	Equipment Required for Tests and Adjustment	5-0	6-1.	List of Reference Designators and Abbreviations	6-1
5-2.	Low Voltage Adjustments	5-2	6-2.	Replaceable Parts	6-3
5-3.	Condensed Adjustment Procedure	5-4	6-3.	Code List of Manufacturers	6-12

Table 1-1. Specifications

PLUG-INS:

Accepts all 1400-series plug-ins; upper compartment for horizontal axis and lower compartment for vertical axis. Plug-ins operate directly into horizontal and vertical deflection plates. Center shield may be removed to provide double-sized compartment for use with a single dual axis 1400-series unit.

CATHODE RAY TUBE:

Type: Post-accelerator storage tube; 7.5 kv accelerating potential; aluminized P31 phosphor; equipped with nonglare safety glass faceplate.
 Graticule: 10 x 10 cm parallax-free internal graticule, marked in centimeter squares; subdivisions of 2 mm on major horizontal and vertical axis, and on second and ninth horizontal graticule lines.
 Intensity Modulation: Approximately +20-volt pulse will blank trace of normal intensity; terminals on rear panel.

PERSISTENCE:

Normal: Natural persistence of P31 phosphor (about 0.1 second).
 Variable: Continuously variable from less than 0.2 second to more than one minute.

WRITING RATE (with Variable Persistence)

NORMAL Mode: Greater than 20 cm/ms.
 MAX Mode: Greater than 1 cm/ μ s.

BRIGHTNESS:

Measured with entire screen faded positive; greater than 200 foot Lamberts.

STORAGE TIME:

Store Mode: Traces can be stored for more than one hour at reduced intensity.
 View Mode: Stored traces can be viewed at normal intensity for a cumulative time of more than one minute.

Erase: Manual; erasure takes approx. 100 msec.

CALIBRATOR:

Type: Line-frequency rectangular signal, approximately 0.5 μ sec rise time.
 Voltage: Two outputs: 1 volt and 10 volts peak-to-peak, $\pm 3\%$ from 0°C to 35°C, $\pm 3\%$ from 0°C to 55°C.

BEAM FINDER:

Pressing BEAM FINDER control brings trace on screen, regardless of setting of horizontal or vertical POSITION, or INTENSITY control.

GENERAL:

Power Requirements: 115 or 230 volts, $\pm 10\%$ AC, 50 to 60 Hz*, normally less than 285 watts (varies with plug-in used). Will provide 140 watts of regulated power to plug-ins.

Dimensions:

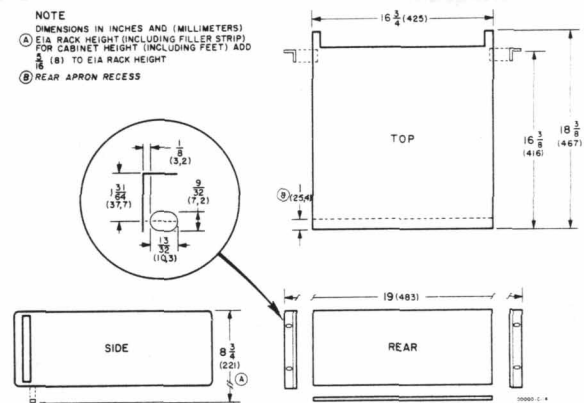

Weight: Net, 37 lbs. (16,7 kg) (without plug-ins). Shipping, 45 lbs. (20 kg).

*This manual incorporates the name hertz, abbreviated Hz, as the unit for frequency.

SECTION I GENERAL INFORMATION

1-1. DESCRIPTION.

1-2. The hp Model 141A, Figure 1-1, is a conventional, general purpose Oscilloscope with the added features of variable persistence (duration of trace afterglow) and storage of CRT displays. Persistence is variable from 0.2 to more than 60 seconds; a display may be stored (at reduced intensity) for more than 1 hour or displayed at normal intensity for up to 1 minute. Stored displays can be erased in 100 milliseconds.

1-3. Variable persistence is especially useful for viewing slow-sweep signals. The persistence of the signals from electrocardiograms or other bio-chemical phenomena can be adjusted to provide a complete trace, yet to fade fast enough to prevent interference with the next trace. Display persistence of swept frequency and time domain reflectometry measurement readouts can be adjusted to eliminate flicker and still provide high resolution.

1-4. The storage feature of the Model 141A can be used to store single-shot waveforms and to later view or photograph the phenomena. Comparison of waveforms can be accomplished by storing several displays separately and then viewing them simultaneously.

1-5. The Model 141A accepts all hp Model 1400-series plug-in units. Amplifiers with bandwidths up to 20 MHz*

and sensitivities to 10 microvolts per centimeter are available as well as time domain reflectometry and swept frequency indicator units. Complete specifications for the Model 141A Oscilloscope are given in Table 1-1.

1-6. CATHODE RAY TUBE.

1-7. The Model 141A uses an internal graticule, P31 aluminized phosphor CRT with additional internal elements to provide the variable persistence and storage features. The tube is equipped with a nonglare safety face plate and the internal graticule eliminates parallax error in observing the display.

1-8. CRT WARRANTY.

1-9. The CRT used in the Model 141A is covered by a warranty separate from the instrument warranty. The CRT warranty is included in the back of this manual for use in the event of CRT failure during the warranty period listed thereon.

1-10. ASSOCIATED EQUIPMENT.

1-11. Some of the plug-ins available for use with the Model 141A are listed in Table 1-2. The Model 141A is normally operated with a vertical plug-in in the lower compartment and a horizontal plug-in in the upper compartment. Both plug-in compartments are

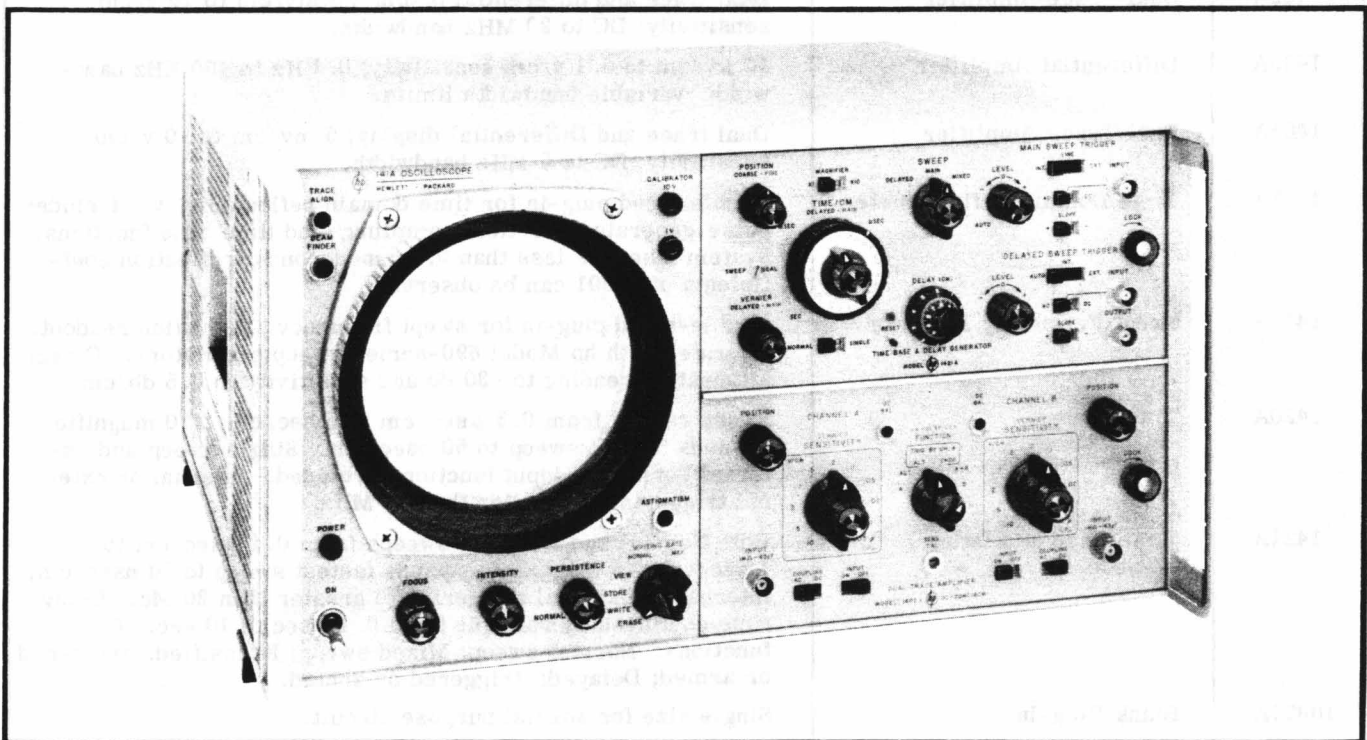

Figure 1-1. Model 141A Oscilloscope

*This manual incorporates the name hertz, abbreviated Hz, as the unit for frequency.

the same size and the plug-in instruments may be interchanged for any special application. The divider shield, which separates the two compartments, may be removed and one double sized plug-in installed. Blank plug-in kits, both single and double sized, are available for user fabrication of special circuits. See Table 4-1 for power supply current limitations.

1-12. MANUAL IDENTIFICATION.

1-13. Information in this manual applies directly to Model 141A instruments with serial prefix of 547-. The serial prefix is the first 3 digits of the eight digit serial number (000-00000) used to identify each Hewlett-Packard instrument. If the serial prefix of a Model 141A is not 547-, a change sheet supplied with the manual will define the difference between that

Model 141A and the one described in this manual, or a different manual may provide the information. Corrections to this manual due to any errors which existed when this manual was printed are called Errata and appear only on the change sheet supplied. For information pertaining to change sheets, contact the nearest Hewlett-Packard Sales/Service Office.

1-14. SCOPE OF MANUAL.

1-15. This manual provides operating and maintenance instructions for the Model 141A Oscilloscope. This information is supplemented by the information contained in the 1400-series plug-in manuals. For information on the operation and maintenance of plug-in units, refer to the manual for that particular instrument.

Table 1-2. Plug-Ins for Model 141A Oscilloscope*

hp Model	Name	Description
1400A	Differential Amplifier	100 $\mu\text{v}/\text{cm}$ to 20 v/cm sensitivity; DC to 400 kHz bandwidth.
1401A	Dual Trace Amplifier	Dual trace and differential display; 1 mv/cm to 10 v/cm sensitivity; DC to 450 kHz bandwidth.
1402A	Dual Trace Amplifier	Dual trace and differential display; 5 mv/cm to 10 v/cm sensitivity; DC to 20 MHz bandwidth.
1403A	Differential Amplifier	10 $\mu\text{v}/\text{cm}$ to 0.1 v/cm sensitivity; 0.1 Hz to 400 KHz bandwidth, variable bandwidth limits.
1405A	Dual Trace Amplifier	Dual trace and Differential display; 5 mv/cm to 10 v/cm sensitivity; DC to 5 MHz bandwidth.
1415A	Time Domain Reflectometer	Double sized plug-in for time domain reflectometry. Includes pulse-generator, vertical sampling, and time base functions. System risetime less than 0.1 nanoseconds; reflection coefficients of 0.001 can be observed.
1416A	Swept Frequency Indicator	Double-sized plug-in for swept frequency attenuation readout. Operates with hp Model 690-series sweep oscillators. Direct attenuation reading to -30 db and sensitivity to 0.5 db/cm.
1420A	Time Base	Sweep ranges from 0.5 $\mu\text{sec}/\text{cm}$ to 5 sec/cm ; X10 magnifier expands fastest sweep to 50 nsec/cm . Single sweep and external horizontal input functions provided. Internal or external triggering to greater than 10 MHz.
1421A	Time Base and Delay Generator	Both Normal and Delaying sweeps from 0.1 $\mu\text{sec}/\text{cm}$ to 1 sec/cm ; X5 magnifier expands fastest sweep to 20 nsec/cm ; internal or external triggering to greater than 20 Mc. Delay time continuously variable from 0.1 μsec to 10 sec. Delay functions: Normal sweep; Mixed sweep; Intensified: triggered or armed; Delayed: triggered or armed.
10477A	Blank Plug-In	Single size for special purpose circuit.
10478A	Blank Plug-In	Double size for special purpose circuit.

* Check latest literature for additional new plug-ins.

SECTION II INSTALLATION

2-1. INITIAL INSPECTION.

2-2. **MECHANICAL CHECK.** If external damage to the shipping carton is evident, ask the carrier's agent to be present when the instrument is unpacked. Check the instrument for external damage such as broken controls or connectors, and dents or scratches on the panel surfaces. If damage is evident, see Paragraph 2-15 for recommended claim procedure. If the shipping carton is not damaged, check the cushioning material and note any signs of severe stress as an indication of rough handling in transit. If the instrument appears undamaged, perform the electrical check (Paragraph 2-3). Retain the packaging material for possible future use.

2-3. **ELECTRICAL CHECK.** Check the electrical performance of the Model 141A as soon as possible after receipt. Paragraphs 5-3 through 5-5 contain performance check procedures which will verify instrument operation within the specifications listed in Table 1-1. Initial performance and accuracy of the instrument are certified as stated on the inside front cover of this manual. If the Oscilloscope does not operate as specified, refer to Paragraph 2-15 for recommended claim procedure.

2-4. PREPARATION FOR USE.

2-5. POWER REQUIREMENTS.

2-6. The Model 141A Oscilloscope requires a power source of either 115 or 230 volts ac, $\pm 10\%$, single phase, 50 to 60 Hz, which can deliver approximately 300 watts. A rear panel switch provides selection of the line voltage to be used.



Be sure to set the rear panel switch for the line voltage to be used. The power supplies may be damaged if the switch is set to the wrong position.

2-7. **230-VOLT OPERATION.** If the instrument is to be operated from a 230-volt source, set the rear panel switch to 230. The line fuse, F401, must be changed to a 2-amp slow-blow fuse for 230-volt operation. The fuse is accessible by removing the bottom cover of the Model 141A; it is identified in Figure 5-1.

2-8. **THREE-CONDUCTOR POWER CABLE.** For the protection of operating personnel, the National Electrical Manufacturers' Association (NEMA) recommends that the instrument panel and cabinet be grounded. The Model 141A is equipped with a detachable, three-conductor power cable which, when plugged into an appropriate receptacle, grounds the instrument. The offset (round) pin on the power cable connector is the ground pin. To preserve the protection feature when

operating the Model 141A from a two-contact outlet, use a three-conductor to two-conductor adapter and connect the green lead on the adapter to ground at the power outlet.

2-9. INSTRUMENT MOUNTING.

2-10. **MODULAR CABINET.** The Model 141A is shipped from the factory as a bench instrument with the tilt stand, feet, and plastic trim in place. The top and bottom panel covers can be removed, giving complete accessibility to all components and adjustments. Sufficient space should be left around the sides of the cabinet to allow unrestricted air circulation.

2-11. **RACK MOUNTING.** A kit for converting the modular cabinet to a rack mount is supplied with each Model 141A. Instructions for making the conversion are given below. Refer to Figure 2-1 as an aid to identifying parts.

a. Detach tilt stand by pressing away from front feet; remove all plastic feet by depressing metal buttons and sliding feet free.

b. Aluminum trim strips (behind each front handle) on sides of instrument have an adhesive back; use a thin-blade tool to remove them.

c. Attach a rack-mounting flange, using screws provided in kit, in each space where trim strip was adhered; larger notch of flange should be positioned at instrument bottom.

d. If Model 141A is to be placed in a rack above or below another hp instrument, attach filler strip provided with kit between front panels of instrument.

2-12. INSTRUMENT COOLING.

2-13. The Model 141A uses a forced-air cooling system to maintain reasonable operating temperatures within the instrument. Warm air is exhausted through the side panel perforations. When operating the instrument, choose a location which provides at least three inches of clearance around the rear and both sides.

2-14. The cooling fan and air filter require periodic lubrication and cleaning. Refer to Paragraph 5-44 for maintenance instructions.

2-15. CLAIMS.

2-16. The warranty statement applicable to all Hewlett-Packard Company instruments and products is provided inside the front cover of this manual. If physical damage is found or if operation is not as specified when the instrument is first received, notify the carrier and the nearest Hewlett-Packard Sales/Service Office immediately. The Sales/Service Office will arrange for repair or replacement of the instrument without waiting for settlement of a claim with the carrier. For other than initial inspection warranty claims, contact the Sales/Service Office.

2-17. REPACKAGING FOR SHIPMENT.

2-18. If the Model 141A is to be shipped to a Hewlett-Packard Sales/Service Office for service or repair, attach a tag showing owner (with address), instrument model number, full serial number of the instrument (all 8 digits) and description of the service or repair required.

2-19. The original shipping carton and packaging material, with the exception of accordion-pleated pads, may be reusable, if undamaged. The Sales/Service Office will provide information and recommendations on materials to be used if the original packaging material is not available. Materials used for shipping an instrument should include the following:

a. A double-walled carton, see Table 2-1 for test strength required.

Table 2-1. Shipping Carton Test Strengths

Gross Weight (lbs)	Carton Strength (test lbs)
up to 10	200
10 to 30	275
30 to 120	350
120 to 140	500
140 to 160	600

b. Heavy paper or sheets of cardboard to protect all instrument surfaces; use a nonabrasive material such as polyurethane or cushioned paper such as Kim-pack around all projecting parts.

c. At least 4 inches of tightly-packed, industry approved shock-absorbing material such as extra firm polyurethane foam.

d. Heavy-duty shipping tape for securing outside of carton.

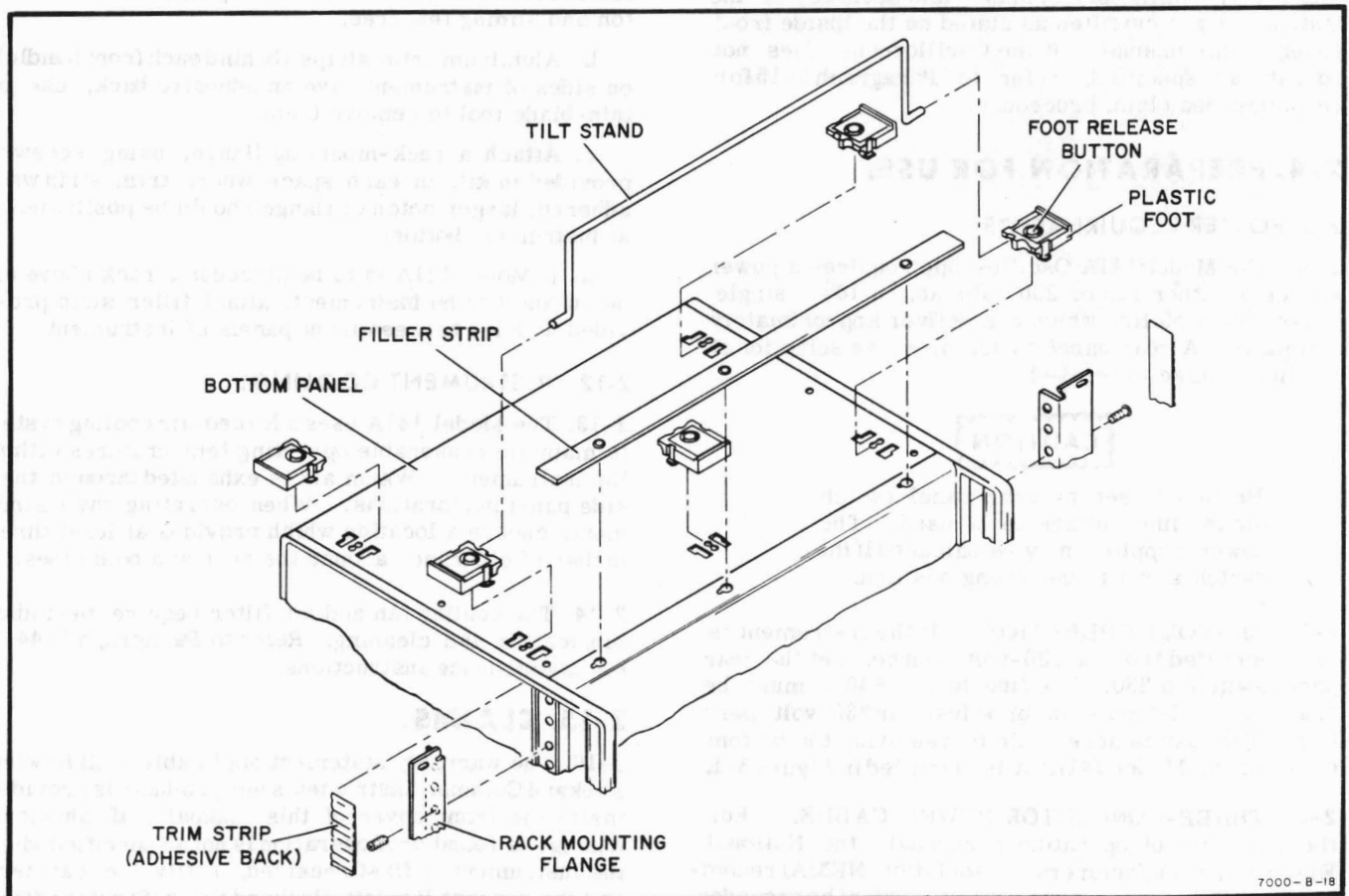

Figure 2-1. Rack Mounting Procedure

SECTION III OPERATION

3-1. INTRODUCTION.

3-2. The Model 141A is a variable persistence, storage Oscilloscope which employs plug-in type vertical and horizontal amplifiers. The controls which affect the operation of the power supplies and cathode ray tube are located on the Model 141A; all other controls are located on the plug-in amplifiers. The Model 141A includes the high and low-voltage power supplies, a calibrator circuit with 1 and 10-volt pk-pk outputs on the front panel, the CRT, and a pulse circuit for variable persistence and storage operation.

3-3. FRONT PANEL COMPONENTS.

3-4. Figure 3-1 identifies the front panel controls and gives a brief functional description of each. Additional information on some of the controls is given below. A more detailed description of some of the controls and their function in variable persistence and storage operation is given in Paragraph 3-17.

3-5. TRACE ALIGN. The TRACE ALIGN adjustment is provided to compensate for manufacturing tolerances and external magnetic fields which may affect the CRT trace. The adjustment should be made when the trace does not appear parallel with the horizontal lines on the CRT graticule. To adjust the TRACE ALIGN, set the Presentation Selector WRITE and adjust a free-running trace on the CRT; rotate the TRACE ALIGN adjustment as required to make the trace parallel to the graticule lines.

3-6. BEAM FINDER. A very high dc input signal may drive the trace off the CRT screen. When the BEAM FINDER is depressed, the trace is intensified and returned to the screen. Adjust the POSITION control to center the beam and when the BEAM FINDER is released, the trace should remain on screen. If the front panel INTENSITY control is fully counter-clockwise, the trace may not be visible. If the trace is not visible when the BEAM FINDER is depressed, set INTENSITY to the 10 o'clock position.

3-7. ASTIGMATISM. The ASTIGMATISM adjustment is provided to insure uniform focus of the trace over the entire CRT screen. To adjust the ASTIGMATISM, set Presentation Selector to WRITE, center a low-intensity spot on the CRT screen (WRITING RATE and PERSISTENCE both in NORMAL) and adjust FOCUS and ASTIGMATISM for a small, round, sharply focused spot.

3-8. REAR PANEL COMPONENTS.

3-9. 115/230 VOLT SWITCH. This switch, located at the bottom of the rear panel, must be set to the position which corresponds to the line voltage to be used. The Model 141A is shipped with a 4-amp fuse installed for 115-volt operation. If the Model 141A is to be connected to a 230-volt outlet, change the fuse to a 2-amp, slow-blow fuse supplied with the instrument.

3-10. Z-AXIS INPUT. The Z-AXIS INPUT terminals and selector switch are on the rear panel of the instrument. To externally modulate the trace intensity, set the switch to EXT, remove the shorting strap and connect the modulation signal to the terminals. The amplitude of the pulse required to blank the trace depends on the front panel INTENSITY control setting, and is approximately 20 volts positive for normal intensity settings. When not using external intensity modulation, connect the strap across the terminals and place the switch to INT.

3-11. PLUG-IN UNITS.

3-12. For normal operation, install a vertical plug-in in the lower compartment and a horizontal plug-in in the upper compartment. The compartment divider must be in place to provide proper shielding between the plug-ins. For double-size plug-in operation, remove the divider. All plug-ins installed should be securely locked in place with the plug-in front-panel LOCK knob.

3-13. Deflection-plate sensitivity may vary slightly from one CRT to another. This may necessitate adjustment of the sensitivity calibration of plug-ins installed in the Model 141A for the first time, or when moved from one Model 141A to another. Refer to the Operating and Service Manual furnished with plug-in unit for the SENS CAL adjustment procedure.

3-14. OPERATING CONSIDERATIONS.

3-15. DEFINITIONS.

3-16. Several words and phrases, the definition of which may vary slightly from common usage, are used to describe the operation of the Model 141A. The definitions of these words and phrases which apply to the Model 141A are as follows:

a. WRITE - To transform an input signal into a visible display on the CRT screen.

b. PERSISTENCE - The length of time a single sweep, written display remains visible on the CRT screen (INTENSITY and Sweep Time Constant).

c. STORE - To retain, at reduced intensity, a display which has been written on the CRT.

d. VIEW - To redisplay on the CRT screen, at normal intensity, a stored display.

e. ERASE - To remove all displays, and blooms which have been stored, or written with persistence on the CRT.

f. INTENSITY - The brightness of a display as it is written on the CRT screen (PERSISTENCE and Sweep Time Constant).

g. BLOOM - A visible, non-symmetrical expansion of a display written on the CRT screen, Par. 3-2.

h. FADE POSITIVE - Display obscured by slow blooming, Figure 3-6.

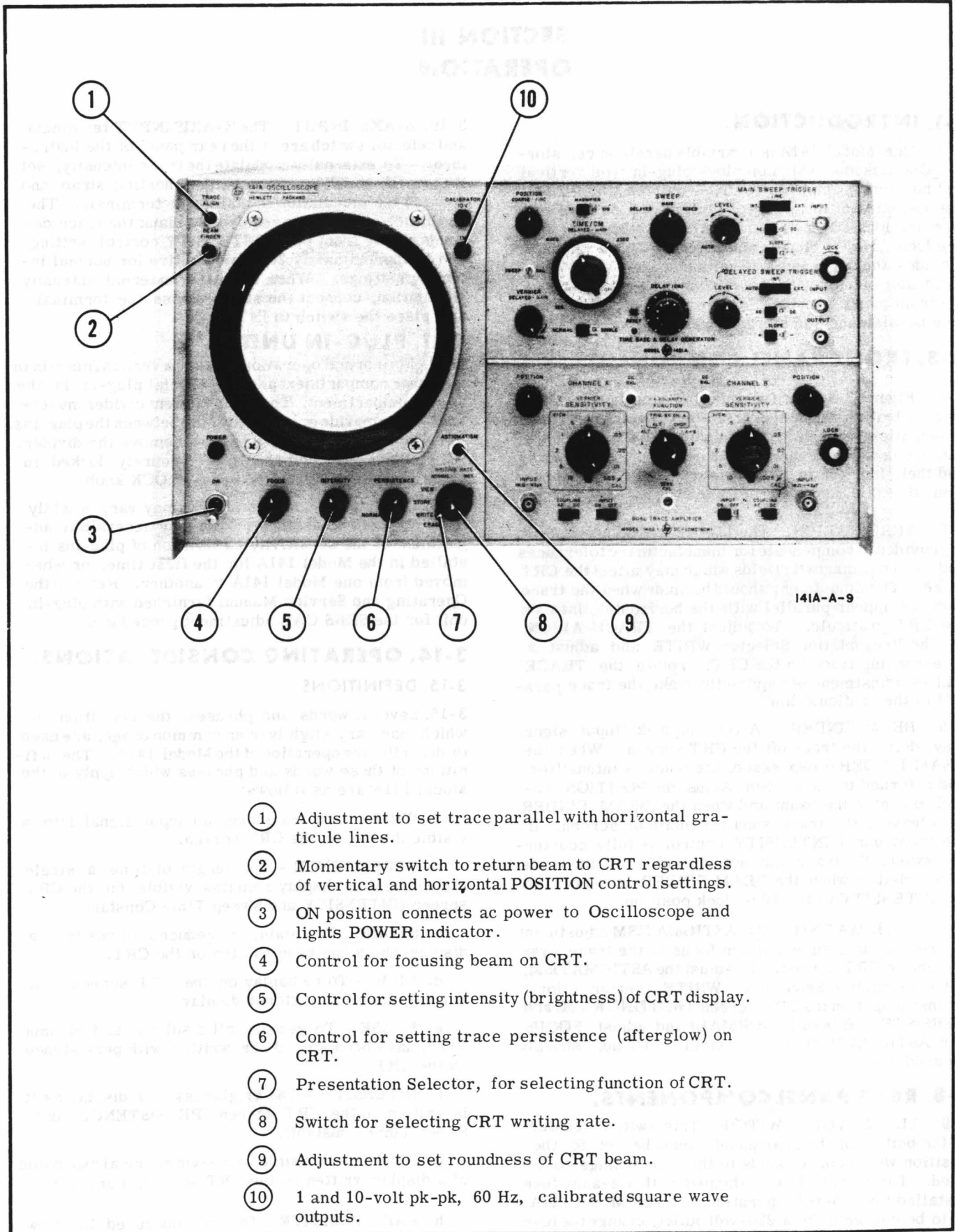

- ① Adjustment to set trace parallel with horizontal graticule lines.
- ② Momentary switch to return beam to CRT regardless of vertical and horizontal POSITION control settings.
- ③ ON position connects ac power to Oscilloscope and lights POWER indicator.
- ④ Control for focusing beam on CRT.
- ⑤ Control for setting intensity (brightness) of CRT display.
- ⑥ Control for setting trace persistence (afterglow) on CRT.
- ⑦ Presentation Selector, for selecting function of CRT.
- ⑧ Switch for selecting CRT writing rate.
- ⑨ Adjustment to set roundness of CRT beam.
- ⑩ 1 and 10-volt pk-pk, 60 Hz, calibrated square wave outputs.

Figure 3-1. Model 141A Controls

i. **BACKGROUND ILLUMINATION** - A green cloud of illumination visible on the CRT screen, Figure 3-2.

j. **SWEEP TIME** - The time (in seconds, milliseconds, or microseconds) required for the beam to move horizontally one unit of distance (centimeter) across the CRT screen, when writing a display.

3-17. CONTROL FUNCTIONS.

3-18. **PERSISTENCE and INTENSITY.** These controls contribute to the duration of afterglow of a display. The **PERSISTENCE** control sets the rate at which a display is erased; **INTENSITY** sets the brightness of the trace as it is written. With a given **PERSISTENCE** setting, the actual duration of trace afterglow may be increased by increasing the **INTENSITY**. Since the **PERSISTENCE** control sets the rate of erasing a written display, it follows that a brighter trace will require more time to be erased. Conversely, a display of low intensity will disappear more rapidly. The same principle applies to a stored display of high and low intensity.



The storage mesh of the CRT is not easily damaged, however, a high-intensity repetitive trace or spot, written on the screen for an extended time, may not erase completely. To prevent CRT damage, use minimum **INTENSITY** which will give the desired display for a given **PERSISTENCE** setting.

3-19. **PRESENTATION SELECTOR.** This control selects the mode in which the CRT functions. In the **ERASE** position, the other three functions are disconnected and all stored and persisting displays are removed from the CRT. The **WRITE** position is the only position on the selector in which a display may be written on the CRT screen. The **STORE** position disconnects the **WRITE** function and retains written displays (at reduced intensity) on the CRT. **INTENSITY** and **PERSISTENCE** do not function in the **STORE** position. The **VIEW** position intensifies the stored display to set a brightness and again, **INTENSITY** and **PERSISTENCE** do not affect the display.

3-20. **WRITING RATE.** In the **MAX** position, the rate of erasing a written display is decreased. Since the erasing rate is decreased, the entire screen becomes illuminated more rapidly and the display is obscured. The effective persistence and storage time are thus considerably reduced.

3-21. OPERATING TIPS.

3-22. This information is provided to aid the operator in becoming familiar with the Model 141A controls and their functions, and to serve as a guide for obtaining the desired CRT display.

a. For conventional Oscilloscope operation, set **WRITING RATE** and **PERSISTENCE** to **NORMAL**, Function Selector to **WRITE** and use minimum **INTENSITY**.

b. For variable persistence operation, use minimum **INTENSITY** and maximum **PERSISTENCE** compatible with the desired display. (See Figure 3-3.)

c. Use **WRITING RATE** in **MAX** only for fast sweep time, single-shot displays, or to improve the uniformity of trace intensity. The **MAX** position causes more rapid positive fading on the CRT and persistence or storage time of the display is thus reduced.

d. To store a display, set the Presentation Selector to **WRITE**, adjust the **INTENSITY** and **PERSISTENCE** for the desired display and rotate the Presentation Selector to **STORE**.

e. To view a stored display, rotate the Presentation Selector to **VIEW**, or set **PERSISTENCE** fully clockwise, **INTENSITY** to fully counterclockwise and rotate Presentation Selector to **WRITE**.

f. To store more than one display, set Presentation Selector to **WRITE**, set **PERSISTENCE** fully clockwise and **INTENSITY** as required; allow first display to be written on the CRT. Set **INTENSITY** fully counterclockwise and connect second signal to be stored. Reset vertical **POSITION** if second display is not to be superimposed on first. Slowly rotate **INTENSITY** clockwise until second display appears. Rotate Presentation Selector to **STORE** and both displays are stored.

g. A display, which is stored when the Model 141A power is turned off, will remain stored for several days. To redisplay the stored waveforms, rotate the Presentation Selector to **VIEW** and the vertical **POSITION** control counterclockwise, before turning the power on. This will prevent a bright spot caused by the initial surge from the write gun.

h. To erase all persistent or stored displays, set Presentation Selector to **WRITE** and rotate **PERSISTENCE** control counterclockwise to (but not in) **NORMAL** detent, or rotate Presentation Selector to **ERASE** for approximately 2 seconds, then release. (First method not effective when **WRITING RATE** is set to **MAX**.)

i. With **WRITING RATE** in **MAX**, **PERSISTENCE** counterclockwise but not in **NORMAL** detent, Presentation Selector in **WRITE** and **INTENSITY** clockwise just enough to make a display visible, the display may possibly be stored. This type of operation may be useful in comparing variations in a repetitive waveform. To observe the multiple displays so stored, rotate the Presentation Selector to **VIEW**.

j. If only a portion of a slow sweep display is desired, switch the Presentation Selector to **STORE** when the trace has been written to the desired point; the write gun is blanked and the written portion is stored.

k. Use a viewing hood, if desired, to improve screen-display contrast.

m. Figures 3-2 through 3-9 are provided to show typical CRT displays with various control settings and input signals. They are examples which, if duplicated by the operator, will aid in understanding the operation of the Model 141A. Figure 3-9 shows small bright spots on the CRT screen which are caused by minute imperfections in the storage mesh.

3-23. SINGLE-SHOT OPERATION.

3-24. To write with persistence or store a single-shot phenomena, trial setting of **INTENSITY** is the best

approach. The amplitude of the phenomena and the sweep-time required to display it will affect the persistence. For example, with maximum PERSISTENCE and some settings of INTENSITY, a single-shot straight-line trace may bloom, Figure 3-4, and a single-shot signal with amplitude variations of several centimeters may not cause blooms, Figure 3-5. To determine the best INTENSITY setting, connect a signal which approximates the sweep time and amplitude of the single-shot signal to be written. Set PERSISTENCE fully clockwise and trigger a single sweep of the test signal. Set the INTENSITY as far clockwise as possible without causing blooming. Repeat the single sweep signal, erasing the display and setting the INTENSITY after each trace until the desired display is obtained. This setup should give maximum persistence to the single-shot display. After the single-shot signal has been written, turn the Presentation Selector to STORE to retain the display.

3-25. Single-shot signals which require a sweep time faster than 20 microseconds per centimeter can be written with more brightness by setting the WRITING RATE to MAX. The screen will be unevenly illuminated after erasing when WRITING RATE is in MAX, however the INTENSITY can be set high enough to make

the display visible through the illumination. A display, written with WRITING RATE set to MAX, will be obscured by positive fading more rapidly than a display written with WRITING RATE set to NORMAL.

3-26. Single-shot signals which require a sweep time between 200 and 20 microseconds per centimeter may have low brightness at the center of the screen. Fire a single-shot test signal with INTENSITY and PERSISTENCE fully clockwise and WRITING RATE in NORMAL, and if the center brightness is low, wait for one to three minutes for the low-brightness area to become brighter. Likewise, if the entire display brightness appears below a usable level, or the display is not visible at all, wait for one to five minutes for the display to appear, Figures 3-7 and 3-8.

3-27. For single-shot signals requiring a sweep time from one to five minutes, set PERSISTENCE and WRITING RATE to NORMAL and INTENSITY as required to prevent blooms. Fire the single-shot signal and after the sweep is completed, rotate Presentation Selector to VIEW and PERSISTENCE out of NORMAL. The complete display may then be viewed for up to one minute or stored (Presentation Selector to STORE) for up to one hour.

Note: A vertical amplifier plug-in, used in the horizontal compartment, may have less than specified bandwidth. Make the high frequency adjustments (plug-in manual) with the amplifier in the horizontal compartments.

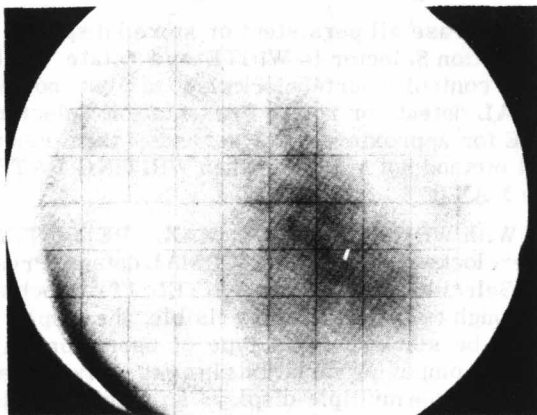

Figure 3-2. Background illumination occurs when erasing with WRITING RATE in MAX

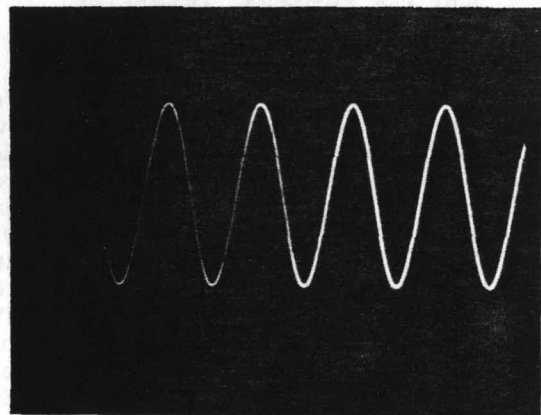

Figure 3-3. Variable persistence with a slow, repetitive sweep

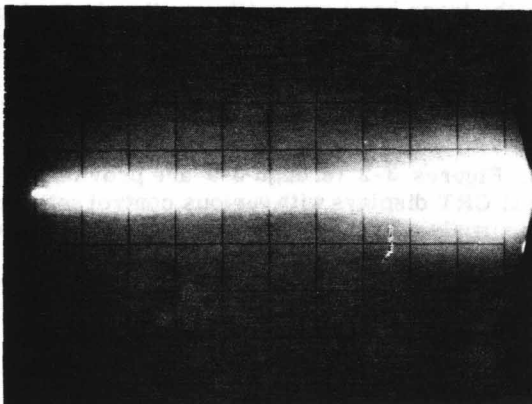

Figure 3-4. Single-shot trace bloom caused by INTENSITY and or PERSISTENCE set too high

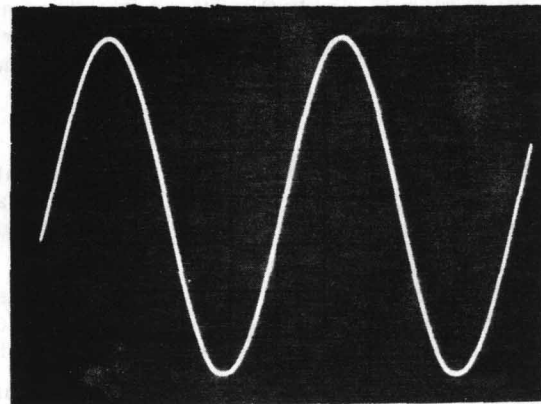

Figure 3-5. Single-shot display with INTENSITY and PERSISTENCE set the same as Figure 3-3

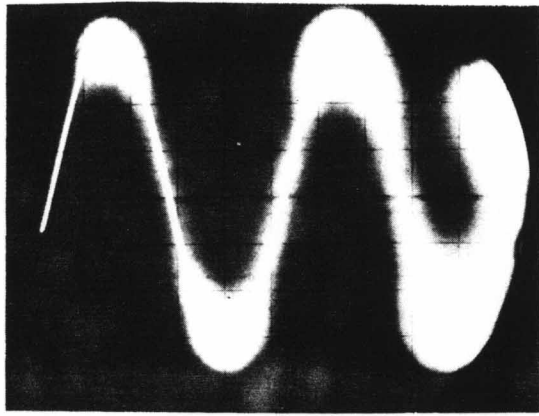

Figure 3-6. Fade positive which occurs after Figure 3-5 display is left in VIEW for 2 to 4 minutes

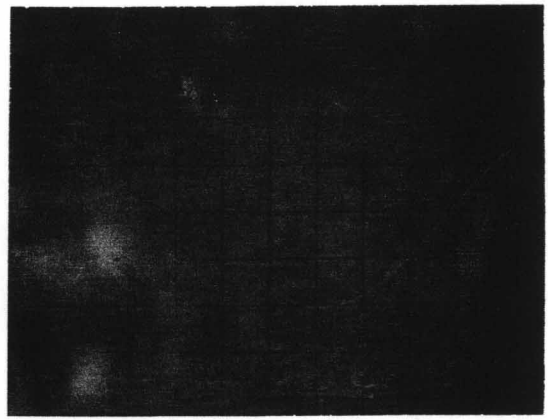

Figure 3-7. Single-shot 20 $\mu\text{sec}/\text{cm}$ display

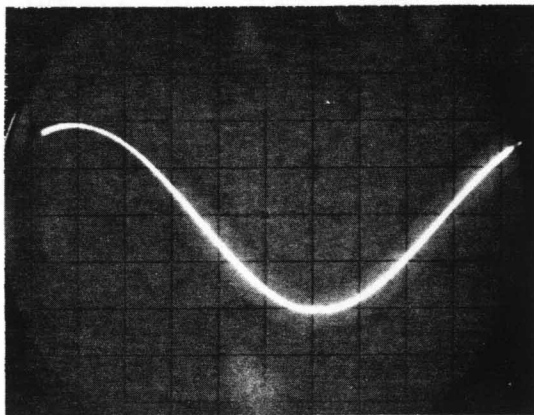

Figure 3-8. Same display as Figure 3-7 after 3 minutes in VIEW

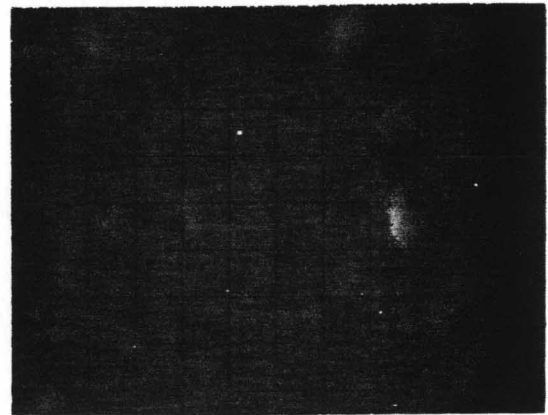

Figure 3-9. Small bright spots caused by minute imperfections in storage mesh

SECTION IV PRINCIPLES OF OPERATION

4-1. OVERALL FUNCTIONAL DESCRIPTION.

4-2. Refer to the block diagram, Figure 4-1, for this explanation. The Model 141A Oscilloscope has four main circuits: a low-voltage supply, a high-voltage supply, a calibrator circuit, and a pulse circuit. The horizontal and vertical amplifier circuits are in the plug-in units and operate directly into the CRT.

4-3. **LOW-VOLTAGE SUPPLY.** The low-voltage supply uses 115 or 230 volts ac (rear panel switch), single phase, 50-60 Hz. Output voltages are -12.6, -100, +100 and +250 volts dc; all outputs are fused and are electronically regulated. Voltages are distributed to the high-voltage supply, the calibrator, pulse circuits, and to the horizontal and vertical plug-ins. 6.3 vac is supplied from the low voltage transformer to the main filament of the CRT and as a signal to the calibrator.

4-4. **CALIBRATOR.** The 6.3 vac applied to the calibrator circuit is shaped into a square wave (of line frequency) and applied to two front panel connectors, 10V and 1V (peak-to-peak amplitude). The 1-volt output is also supplied to the vertical and horizontal plug-ins for sensitivity calibration. Accuracy of the calibrating signal is $\pm 1\%$.

4-5. **HIGH-VOLTAGE SUPPLY.** A transistorized oscillator and a step-up transformer are used to generate negative and positive high voltages for the CRT. Both the +5000-volt and -2350-volt supplies are electronically regulated.

4-6. **PULSE CIRCUIT.** This circuit generates a pulse of variable level and width. The pulse and other dc voltages from the circuit are applied to the storage and persistence elements in the CRT. All voltages from the low-voltage supply are used in the pulse circuit.

4-7. CIRCUIT DESCRIPTION.

4-8. LOW-VOLTAGE SUPPLY.

4-9. The low-voltage supply consists of an independent -100-volt and three dependent supplies (-12.6, +100 and +250). The -100-volt supply is a reference for the other three supplies. The +250 volts is obtained by stacking a +150-volt supply on the +100-volt supply.

4-10. Figure 4-2 is a simplified block diagram of regulator used in the low-voltage supply. The series regulator acts as a variable resistance in the regulated output. A sensor (or differential amplifier) compares the output voltage with a reference voltage (dc return

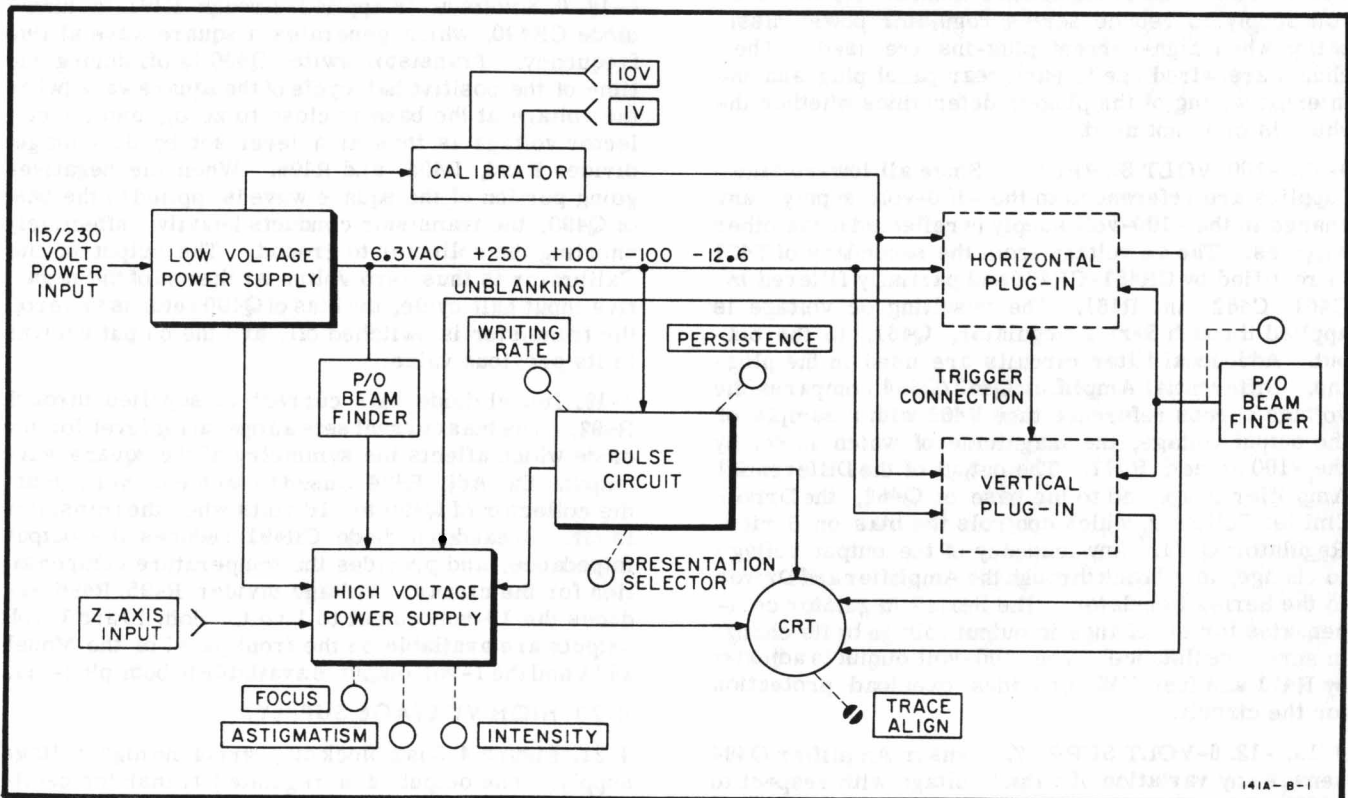

Figure 4-1. Model 141A Block Diagram

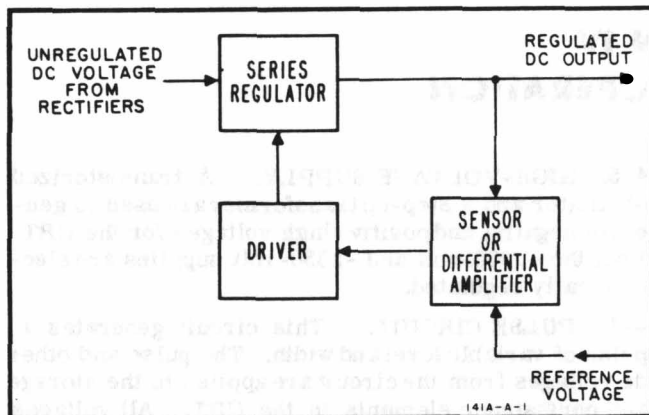

Figure 4-2. Regulated Power Supply Block Diagram

for the supply). The driver (emitter follower or amplifier) controls the bias on the series regulator, which effectively controls the series resistance. Any change in output voltage is fed back to the series regulator. The change in series resistance and the resulting voltage drop is opposite to the output voltage change; thus the output voltage is maintained at a constant level.

4-11. Figure 5-7 is a schematic diagram of the low voltage supply. The primary winding of transformer T401 is wired through a rear panel switch for quick conversion to either 115 or 230-vac operation. Line voltage is applied to the primary of T401 through an on-off switch, a fuse and a thermal switch. A pilot lamp is provided to indicate when power is applied to T401. Two shunt resistors are connected to the +250-volt supply to reduce series regulator power dissipation when high-current plug-ins are used. The shunts are wired one to each rear panel plug and the internal wiring of the plug-in determines whether the shunt is or is not used.

4-12. -100-VOLT SUPPLY. Since all low-voltage supplies are referenced to the -100-volt supply, any change in the -100-volt supply is reflected in the other supplies. The ac voltage from the secondary of T401 is rectified by CR461-CR464 and partially filtered by C461, C462, and R461. The resulting dc voltage is applied through Series Regulator, Q461, to the output. Additional filter circuits are used in the plug-ins. Differential Amplifier Q463/Q464 compares the voltage across reference tube V461 with a sample of the output voltage, the magnitude of which is set by the -100 adjust, R471. The output of the Differential Amplifier is applied to the base of Q462, the Driver Emitter Follower, which controls the bias on Series Regulator Q461. Any tendency of the output voltage to change, is fed back through the Amplifier and Driver to the Series Regulator. The Series Regulator compensates for the change in output voltage by its change in series resistance. The -100-volt output is adjusted by R471 and fuse F461 provides overload protection for the circuit.

4-13. -12.6-VOLT SUPPLY. Sensor Amplifier Q484 senses any variation of output voltage with respect to -100 volts and applies the error voltage to Driver Amplifier Q482. The Driver increases signal current to the level required to control Series Regulator Q481.

The -12.6-volt output is adjusted by R488. Current Limiter, Q483, a protective circuit for the Series Regulator, is normally biased off. If a short occurs across the -12.6-volt output, the base of Q483 goes negative by the voltage drop across R483 minus the forward breakdown voltage of CR483, thus turning Q483 on. The increased positive voltage on the collector of Q483 is applied through Q482 to the base of Series Regulator Q481, biasing it off. The current which then flows through the external short is limited to the current required to keep Q483 on. Additional overload protection is provided by fuse F481.

4-14. +100-VOLT SUPPLY. Differential Amplifier Q443/Q444 in the +100-volt supply senses any variation in output voltage with respect to -100 volts. The error voltage is applied through Driver Q442, to Series Regulator Q441, as corrective bias. Regulation of the output is accomplished in the same manner as in the -100-volt supply. R453 adjusts the +100-volt output and fuse F441 provides overload protection.

4-15. +250-VOLT SUPPLY. Sensor Amplifier Q423 in the +250-volt supply senses any variation in the output voltage, with respect to -100 volts. The error voltage is amplified by Driver Q422 which applies corrective bias to Series Regulator Q421. R432 adjusts the +250-volt output and fuse F421 provides overload protection.

4-16. CALIBRATOR.

4-17. The schematic diagram of the Calibrator circuit is shown in Figure 5-7. The circuit consists of three parts: a tunnel diode square wave generator, a transistor switch, and a calibration network.

4-18. 6.3 volts ac is applied through R491 to tunnel diode CR490, which generates a square wave at line frequency. Transistor switch Q490 is off during the time of the positive half cycle of the square wave (when the voltage at the base is close to zero), and the collector voltage is thus at a level set by dc voltage divider R493, R495, and R496. When the negative-going portion of the square wave is applied to the base of Q490, the transistor conducts heavily, effectively shorting the collector to ground. The output of the Calibrator is thus zero volts. At the end of the negative input half cycle, the bias of Q490 returns to zero, the transistor is switched off, and the output returns to its previous value.

4-19. Tunnel diode bias current is supplied through R492. The bias current sets an operating level for the diode which affects the symmetry of the square wave output. Cal Adj, R494 is used to set the dc voltage at the collector of Q490 to -10 volts when the transistor is off. Breakdown diode CR491 reduces the output impedance, and provides the temperature compensation for the circuit. Voltage divider R495/R496 reduces the 10-volt output to 1 volt. Both 10 and 1-volt outputs are available on the front panel of the Model 141A and the 1-volt output is available to both plug-ins.

4-20. HIGH-VOLTAGE SUPPLY.

4-21. Figure 4-3 is a block diagram of the high-voltage supply. The output of a regulated transistor oscillator is stepped up in voltage and applied to a series of high voltage rectifiers. The positive output of the voltage doubler is connected to the post-accelerator

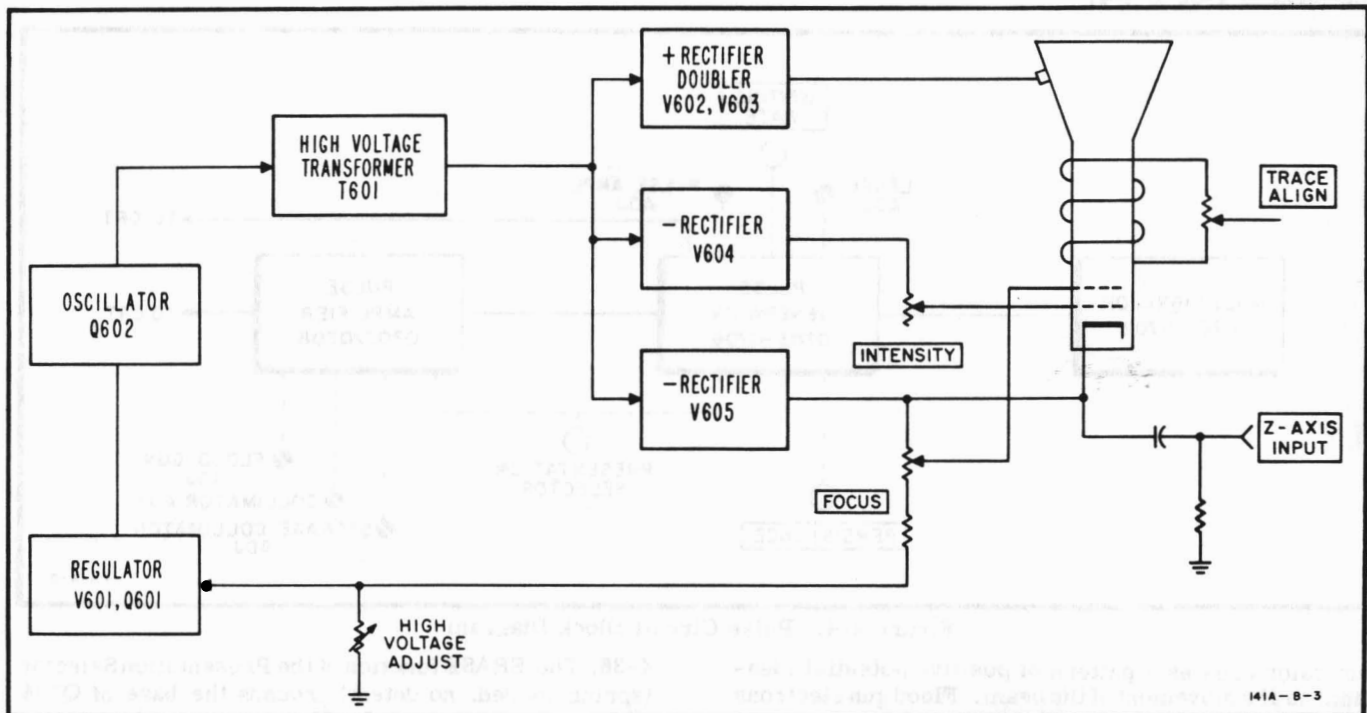

Figure 4-3. High-Voltage Power Supply Block Diagram

of the CRT. The negative output voltages are used in the gun assembly of the CRT and its associated controls. The Z-axis input can be used to apply intensity modulating signals to the CRT.

4-22. Figure 5-8 is a schematic diagram of the high-voltage supply and the CRT. Oscillator Q602 operates at a frequency of approximately 32 kHz. Any change in the output voltage is applied to the grid of V601, which converts the voltage change to a current change. This current change is applied, by Emitter Follower Q601, to the base of the oscillator transistor. The amplitude of oscillations is changed in such a direction as to oppose the original output voltage change. High-Voltage Adjust R619 sets the amplitude of oscillation to produce the correct output voltage.

4-23. Two separate negative supplies are used, one for the control grid of the CRT, and one to provide CRT cathode and focusing voltages. Both supplies use half wave rectifiers (V604 and V605). The unblanking gate from the horizontal plug-in (pin 1, J2) is applied to the return side of the grid supply, and changes the negative grid voltage by about +50 volts to unblank the trace. A positive pulse of about 20 volts will blank the trace when applied to Z-axis input. When Z-axis input is not used, S601 is set to INT to receive chopped blanking from a dual-trace plug-in.

4-24. The voltage doubler circuit provides the 5-kv post-accelerating voltage applied to the CRT.

4-25. The ASTIGMATISM adjustment, R461, affects the roundness of the spot, and the Geometry adjustment, R643, is used to optimize pattern shape.

4-26. STORAGE CRT.

4-27. Refer to Figure 5-8 for the schematic diagram of the storage CRT, V610. The CRT contains the conventional electron (writing) gun, deflection plates,

post-accelerator, and phosphor screen. In addition, there are two flood guns (filaments, cathodes, and grids only), a collimator, a collector mesh, and a storage mesh. These added elements make possible the variable persistence and storage functions of the Model 141A.

4-28. FLOOD GUNS. The flood guns are physically located on the electron gun outside of the horizontal deflection plates. Horizontal Drivers, Q603, and Q604 prevent flood gun electrons from flowing through the deflection plates to the output stage of the plug-in. The gun operates continuously when the power switch is on. An electron cloud, which is emitted by the flood guns, is accelerated toward the CRT screen by collimator and collector mesh voltages. These electrons make stored or persisting displays visible. They are also used to erase stored and persisting displays.

4-29. COLLIMATOR. The collimator is an internal coating along the tapered portion of the CRT. A positive voltage applied to the collimator focuses the flood-gun electrons. The cloud electrons are formed into a column perpendicular to, and approximately equal to the diameter of, the CRT screen.

4-30. COLLECTOR MESH. The collector mesh is between the flood guns and the storage mesh (closest to the storage mesh). It is always positive with respect to the storage mesh except in the ERASE position of the Presentation Selector; both are then at the same potential. In addition to accelerating flood gun electrons, the collector mesh also repels positive ions generated by the flood guns.

4-31. STORAGE MESH. The storage mesh is just behind the CRT screen and is coated with non-conducting material. It is statically held at a slightly positive potential (approximately +3 volts). When the electron beam from the writing gun strikes the mesh coating, secondary electrons are emitted. This secondary

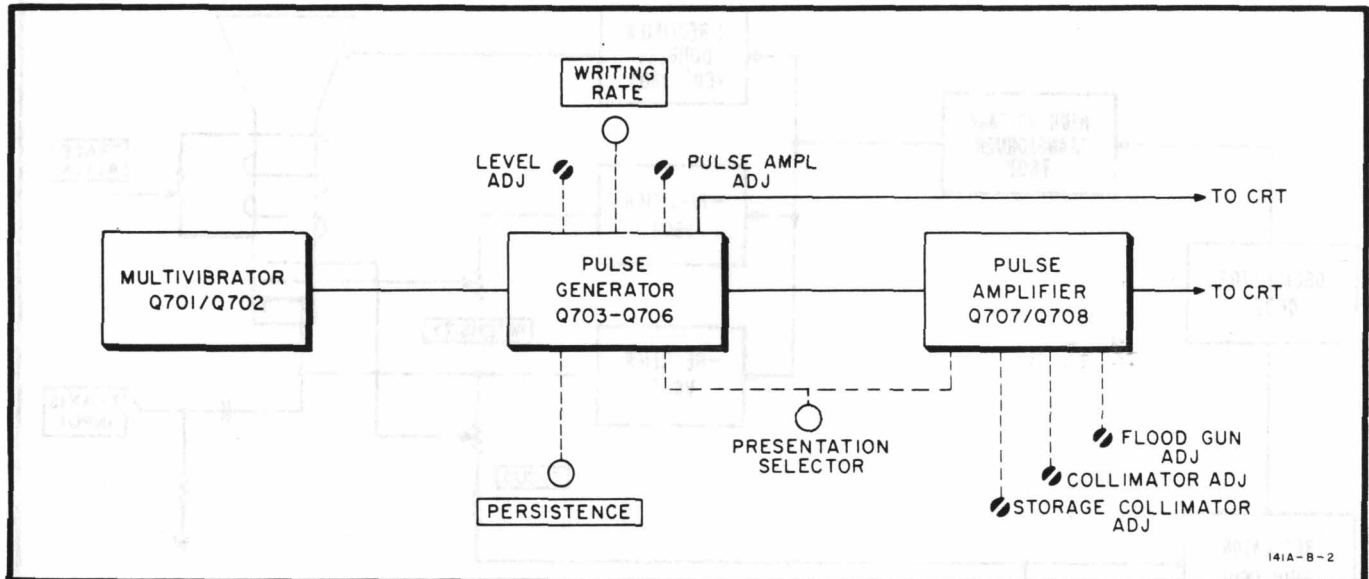

Figure 4-4. Pulse Circuit Block Diagram

emission creates a pattern of positive potential identical to the movement of the beam. Flood gun electrons are accelerated by this positive potential pattern and strike the phosphor screen, thus creating a visible display.

4-32. The storage mesh is continuously pulsed with a variable width pulse of approximately +11 volts. These pulses erase the positive pattern on the storage mesh by discharging the mesh coating. Time required for this erasing operation is determined by the width of the positive pulse. The positive pattern on the mesh may also be neutralized manually by connecting the collector and storage meshes (ERASE). The high positive potential (approximately +156 volts) allows more uniform discharging of the surface. When the storage mesh is disconnected from the collector mesh and returned to +3 volts, the coated surface is at a uniformly equal potential of -9 volts. In both cases, the screen has no illumination. The pattern may be lost by the storage mesh fading positive and allowing the entire screen to be illuminated. This occurs when positive ions from the flood gun raise the surface potential of the storage mesh in random areas sufficiently to allow flood gun electrons to strike the screen.

4-33. PULSE CIRCUIT.

4-34. Figure 4-4 is a block diagram of the pulse circuit. A free running Multivibrator triggers a Pulse Generator. The pulse width can be varied in the Pulse Generator stage. The output from the Pulse Generator is applied to the CRT storage mesh and controls the display persistence. The pulse generator output is also amplified and applied to the CRT collimator.

4-35. Figure 5-11 is a schematic diagram of the pulse circuit. The multivibrator, Q701/Q702, free-runs at approximately 1200 Hz. The output is a rectangular wave which varies between -11 and -0.2 volts. This rectangular wave is differentiated in the base circuits of Q703 and Q704. The pulse at the emitter of Q704 is used to turn off Q705. The signal at the collector of Q705 is applied to emitter follower, Q706.

4-36. The ERASE function of the Presentation Selector (spring-loaded, no detent) grounds the base of Q704 and no pulse is generated. The storage mesh is erased by connecting it to the collector mesh which is held constant at +156 volts dc. The write gun is also blanked by -100 volts applied through S701 and R733 to the high-voltage power supply.

4-37. The STORE function of the Presentation Selector removes the erase pulse from the storage mesh and connects the mesh to C715. This isolates the storage mesh and allows it to retain any pattern which has been written on it. Also in STORE, the pulse at the emitter of Q706 is amplified by Q707/Q708 and applied to the collimator. R727 and R728 are placed in parallel with R725 allowing adjustment of the amplitude of the collimator pulse. This reduces the quantity of positive ions generated by the flood guns and thereby reduces the positive fading of the storage mesh. The write gun is blanked as in ERASE.

4-38. When the Presentation Selector is set to VIEW, the collimator is again at a positive dc potential (approximately +55 volts). Flood gun electrons are accelerated toward the screen and the pattern on the storage mesh is again visible at full brightness. The pulse at the base of Q704 is grounded, the storage mesh is isolated and the write gun is blanked the same as in ERASE.

4-39. The WRITING RATE switch, in the MAX position, alters the collimator operation by holding the Q708 collector at +45 volts (from CR705). The dc level of the storage mesh is lowered as explained in Paragraph 4-35 above.

4-40. TRACE ALIGN.

4-41. The trace align coil, L602 is located around the CRT near the screen. Adjustment of Trace Align R650A/B varies the magnitude and direction of current through the coil, which has the effect of rotating the trace. In this way the trace is brought into alignment with the CRT graticule.

4-42. PLUG-IN KIT FABRICATION.

4-43. The hp Model 10477A and Model 10478A Accessory Plug-Ins are blank plug-in units for the Model 141A Oscilloscope. These two units permit the user of the Oscilloscope to design his own special-purpose circuits. Current available from each of the Model 141A power supply voltages is shown in Table 4-1. Power requirements should not exceed the capabilities shown in the table.

Table 4-1. Current Capability

Supply Voltage	Current Available At Each Jack (J1 and J2)
+250 vdc	0-100 ma
+100 vdc	0-137.5 ma
-100 vdc	10-200 ma
-12.6 vdc	0-0.9 amp
6.3 vac	0-3.25 amp

(This area contains a very faint, illegible table, likely a continuation of Table 4-1 or related technical specifications.)

Table 5-1. Equipment Required for Tests and Adjustments

Recommended Instrument	Model	Required for	Ref Par.	Required Characteristics
Voltmeter Calibrator	hp 738AR or 738 BR	Calibrator check; High Voltage Adjust- ment; Calibrator Adjust- ment	5-5 5-13 5-17	Outputs of 1 v and 10 v pk-pk; -300 v dc; $\pm 0.2\%$
DC Voltmeter	hp 412A	Low-voltage Adjust- ments	5-11	-100 to +100 volts, $\pm 1\%$
DC VTVM	hp 410B/C	High-Voltage Adjust- ment	5-13	May be adapted for high voltage (-2.5 kv) measurement. Provi- sion for altering calibration.
Voltage Divider	hp 11044A hp 11045A	High-Voltage Adjust- ment	5-13	Provide 100:1 division for vtvm; 2.5 and 30 kv rating.
Audio Oscillator	hp 200CD	Geometry Adjustment	5-16	400 kHz output.
Low-Freq Oscilloscope	hp 140A	Coll Stor Adj	5-22	Sensitivity 0.2 to 1 v/cm, Sweep Time 20 μ s/cm to 1 ms/cm.

SECTION V MAINTENANCE

5-1. INTRODUCTION.

5-2. This section covers maintenance, troubleshooting, and adjustment of the Model 141A Oscilloscope. A performance check is included which may be used at incoming inspection, or after adjustments have been made, to verify that the instrument meets specifications.

5-3. PERFORMANCE CHECK.

5-4. CRT CONTROLS.

- a. Install a single large plug-in or two small plug-in units in the Model 141A (vertical plug-in in the lower compartment, horizontal in the upper compartment).
- b. Set INTENSITY fully counterclockwise.
- c. Set PERSISTENCE counterclockwise just out of NORMAL detent and Presentation Selector to WRITE.
- d. Set POWER switch to ON.
- e. Check that CRT screen is lightly and evenly illuminated.



If the CRT screen is not lightly illuminated, turn POWER off and check that all CRT neck and bulb leads are connected. DO NOT rotate INTENSITY clockwise or the CRT may be damaged.

- f. Rotate PERSISTENCE into NORMAL detent and depress BEAM FINDER switch. A defocused spot should appear on the screen.
- g. Set INTENSITY control to 10 o'clock and return beam to screen with POSITION controls. Check that counterclockwise rotation of INTENSITY control extinguishes beam and clockwise rotation gives brighter than normal intensity. Immediately return INTENSITY to 10 o'clock.
- h. The FOCUS and ASTIGMATISM adjustments should have sufficient range to defocus the beam in both extreme positions and should give a sharp, round spot when close to mid-range. Adjust both controls for the sharpest display.
- i. The magnetic field in which the Model 141A is operated will affect the alignment of the trace on the CRT. Set a free-running trace and adjust the TRACE ALIGN to make the trace parallel with the horizontal graticule line.
- j. Set a free-running, 1 MSEC/CM trace and center both POSITION controls.
- k. Rotate INTENSITY control slowly clockwise until a trace appears.

m. Change sweep time to 0.2 SEC/CM and observe that the trace disappears and that the moving beam spot has no tail.

n. Rotate PERSISTENCE slowly clockwise and note that beam spot develops a tail; fully clockwise makes the complete trace remain on the screen.

p. Rotate INTENSITY fully counterclockwise; trace should remain visible for one minute.

q. Rotate INTENSITY slowly clockwise until trace blooms, then fully counterclockwise.

r. Rotate Presentation Selector to ERASE for two seconds and release; screen should be dark.

s. Rotate INTENSITY slowly clockwise until trace has normal intensity, then fully counterclockwise.

t. Rotate PERSISTENCE counterclockwise, screen should be lightly illuminated and trace should disappear; rotate PERSISTENCE fully clockwise and screen should be dark.

u. Repeat step s.

v. Rotate Presentation Selector to STORE; trace should remain visible at low intensity for one hour. Trace may be viewed, at normal intensity, any time during the hour of storage by rotating the Presentation Selector to VIEW. Viewing time decreases as time in storage increases.

w. Set sweep time to 1 μSEC/CM, Presentation Selector to WRITE, and WRITING RATE to MAX.

x. Rotate Presentation Selector to ERASE for 2 seconds and release; screen should appear evenly illuminated.

y. Rotate INTENSITY slowly clockwise until trace appears.

z. Set horizontal plug-in for single sweep.

aa. Rotate Presentation Selector to ERASE for 2 seconds and release.

bb. Arm sweep (if necessary) and trigger a single sweep.

cc. Trace should appear and remain on the screen for a short time, then the entire screen should slowly fade positive (total illumination).

5-5. CALIBRATION.

a. Set: Vertical SENSITIVITY 0.05 V/CM
INPUT coupling DC
PERSISTENCE NORMAL detent

b. Connect 1 VOLT pk-pk from the Voltmeter Calibrator to vertical INPUT.

c. Adjust vertical VERNIER for exactly 10 cm deflection.

d. Disconnect the Voltmeter Calibrator and connect the 1V CALIBRATOR output to the vertical INPUT.

- e. Deflection should be 10 cm ± 0.1 cm.
- f. Repeat steps a through e, using 0.5 V/CM vertical SENSITIVITY and 10 volts from the Voltmeter Calibrator.

5-6. ADJUSTMENTS.

5-7. The adjustment procedures for the Model 141A are given in Paragraphs 5-11 through 5-22. Test equipment required is listed in Table 5-1. Similar test equipment having the required characteristics may be substituted for that recommended in the table. If difficulty is encountered in making any adjustment, refer to Paragraph 5-23 for troubleshooting procedures.

5-8. PRELIMINARY SETUP. Plug-ins should be installed in both compartments when power supply adjustments are made; proper regulation may not occur with no current load connected.

5-9. ADJUSTMENT COMPONENT IDENTIFICATION. All internal adjustment components are identified in Figure 5-1.

5-10. CONDENSED ADJUSTMENT PROCEDURE. Table 5-3 is a condensed adjustment procedure. The table may be useful after becoming familiar with the step-by-step procedures.

5-11. ADJUSTMENTS OF LOW-VOLTAGE SUPPLY.

5-12. Measure the output of each low-voltage supply, and adjust it to the value shown in Table 5-2. Measurement may be made on any wire bearing the indicated color code.

Table 5-2. Low-Voltage Adjustments

Supply (Volts)	Wire Color Code	Adjustment
-100	Violet	-100V Adj R471
-12.6	White/Violet	-12.6V Adj R488
+100	White/Red	+100V Adj R453
+250	Red	+250V Adj R432

5-13. ADJUSTMENTS OF HIGH-VOLTAGE SUPPLY.

- a. Connect the Voltage Divider to the DC probe of a Model 410B/C Voltmeter.
- b. Set Voltmeter to 3-volt -DC range.
- c. Set the Voltmeter Calibrator for -300 volts DC output, and connect divider tip to the output.
- d. Set the gain adjustment of the Model 410B/C (located at the rear of the instrument) for a reading of exactly 3 volts.
- e. Set the Voltmeter to the 30-volt range, and measure the high voltage supply. This may be done at the junction of R651 and R652.
- f. Set High Voltage Adjust R619 for -2350 volts.
- g. Recalibrate the Model 410B/C.

5-14. INTENSITY LIMIT ADJUSTMENT.

- a. Center a defocused spot on the CRT.

- b. Set INTENSITY to 10 o'clock.
- c. Adjust Intensity Limit R612 until spot is just extinguished.

5-15. ASTIGMATISM ADJUSTMENT.

- a. Center a low-intensity spot on the CRT.
- b. Adjust FOCUS and ASTIGMATISM for a small, round, sharply-focused spot.

5-16. GEOMETRY ADJUSTMENT.

- a. Set: TRIGGER LEVEL AUTO
SWEEP TIME 0.2 MSEC/CM
- b. Connect a 400-kHz signal from the Audio Oscillator to the vertical INPUT of the amplifier plug-in.
- c. Adjust vertical and horizontal controls to obtain a pattern 8 cm high.
- d. Adjust Geometry R643 to obtain the straightest possible edges on the rectangular pattern.

5-17. CALIBRATION ADJUSTMENT.

- a. Connect a 10 VOLT Pk-Pk signal from the Voltmeter Calibrator to the vertical amplifier INPUT.
- b. Set amplifier SENSITIVITY to 0.5V/CM, INPUT coupling to DC.
- c. Adjust vertical VERNIER for exactly 10 cm deflection.
- d. Disconnect the Voltmeter Calibrator, and connect the 10V CALIBRATOR output to the amplifier INPUT.
- e. Set Cal Adj R494 for exactly 10 cm deflection.

5-18. PULSE CIRCUIT ADJUSTMENT.

5-19. PULSE AMPLITUDE ADJUSTMENT. The Pulse Ampl. Adj, R714 should be adjusted to the fully clockwise position. Note the typical waveform for test point 7.

5-20. FLOOD GUN AND COLLIMATOR WRITE ADJUSTMENT. No test equipment is required for this adjustment.

- a. Set Presentation Selector to WRITE, PERSISTENCE counterclockwise to, but not in, NORMAL detent, and WRITING RATE to MAX.
- b. Adjust Flood Gun Adj, R726 for maximum diameter illumination of the screen with no dark areas.
- c. Switch WRITING RATE to NORMAL.
- d. Adjust Coll Write Adj, R725, so two rings of illumination are on the circumference of the viewing area of the screen. (See Figure 3-2.)

Note

The two rings of illumination may not be exactly concentric.

5-21. LEVEL ADJUSTMENT. No test equipment is required for this adjustment.

- a. Set Presentation Selector to WRITE, PERSISTENCE fully clockwise and WRITING RATE to MAX.

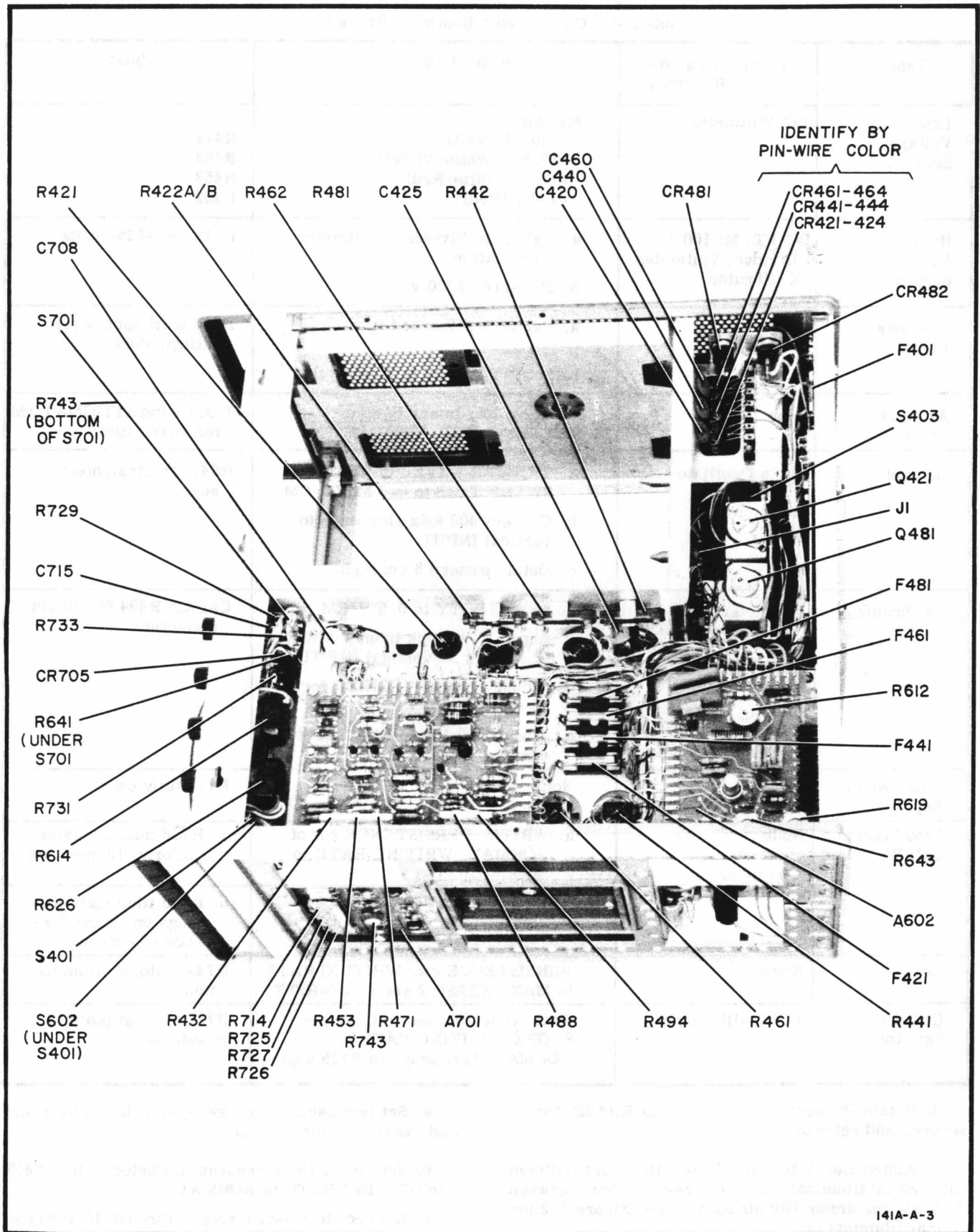

141A-A-3

Figure 5-1. Adjustment and Component Locations, Bottom view

Table 5-3. Condensed Adjustment Procedure

Test	External Equipment Required	Procedure	Adjust
Low Voltage Supplies	DC Voltmeter	Measure: -100 v (Violet) -12.6 v (White/Violet) +100 v (White/Red) +250 v (Red)	R471 R488 R453 R432
High Voltage Supply	DC VTVM; 100:1 Divider; Voltmeter Calibrator	a. Calibrate Divider - Voltmeter combination. b. Measure -2350 v	R619 for -2350 volts
Intensity Limit	None	a. Center a defocused spot. b. Set INTENSITY to 10 o'clock.	R612 until spot is just extinguished.
Astigmatism	None	Center a low-intensity spot.	FOCUS and ASTIGMATISM for sharp spot.
Geometry	Audio Oscillator	a. TRIGGER LEVEL to AUTO SWEEP TIME to 0.2 MSEC/CM b. Connect 400 kHz sine wave to vertical INPUT. c. Obtain pattern 8 cm high.	R643 for straightest edges.
Calibrator	Voltmeter Calibrator	a. SENSITIVITY to 0.5 V/CM b. Apply 10 v pk-pk from Voltmeter Calibrator to vertical INPUT. c. Adjust vertical VERNIER for 10 cm deflection. d. Connect 10 V CALIBRATOR to vertical INPUT.	Cal Adj R494 for 10 cm deflection.
Pulse Ampl Adj	None	None	R714 fully cw.
Flood Gun and Coll Write Adj	None	a. WRITE, PERSISTENCE out of NORMAL, WRITING RATE to MAX	a. R726 max diameter uniform illumination.
		b. WRITING RATE to NORMAL	b. R725 illumination rings on circumference of screen
Level Adj	None	PERSISTENCE cw, WRITING RATE to MAX, ERASE 2 sec then WRITE	R743 uniform illumination
Coll Storage Adj	LF Oscilloscope	Test scope 20 μ sec/cm, 1v/cm STORE, WRITING RATE to NORMAL, test scope to R725 wiper.	R727 for test point 11 waveform

b. Rotate Presentation Selector to ERASE for 2 seconds and release.

c. Adjust Level Adj, R743, for the most uniform background illumination of the screen (midway between dark and maximum illumination). See Figure 3-2 for typical illumination.

5-22. COLLIMATOR STORAGE ADJUSTMENT. The low-frequency oscilloscope is required for this adjustment.

a. Set test oscilloscope sweep time for 20 μ sec/cm and sensitivity for 1 v/cm.

b. Set Model 141A Presentation Selector to STORE and WRITING RATE to NORMAL.

c. Connect test oscilloscope, through 10:1 divider probe, to wiper of R725 (test point 11).

d. Adjust Coll Store Adj, R727, for a 55 to 60-volt pulse. (Correct pulse shown for test point 11 in Table 5-7.)

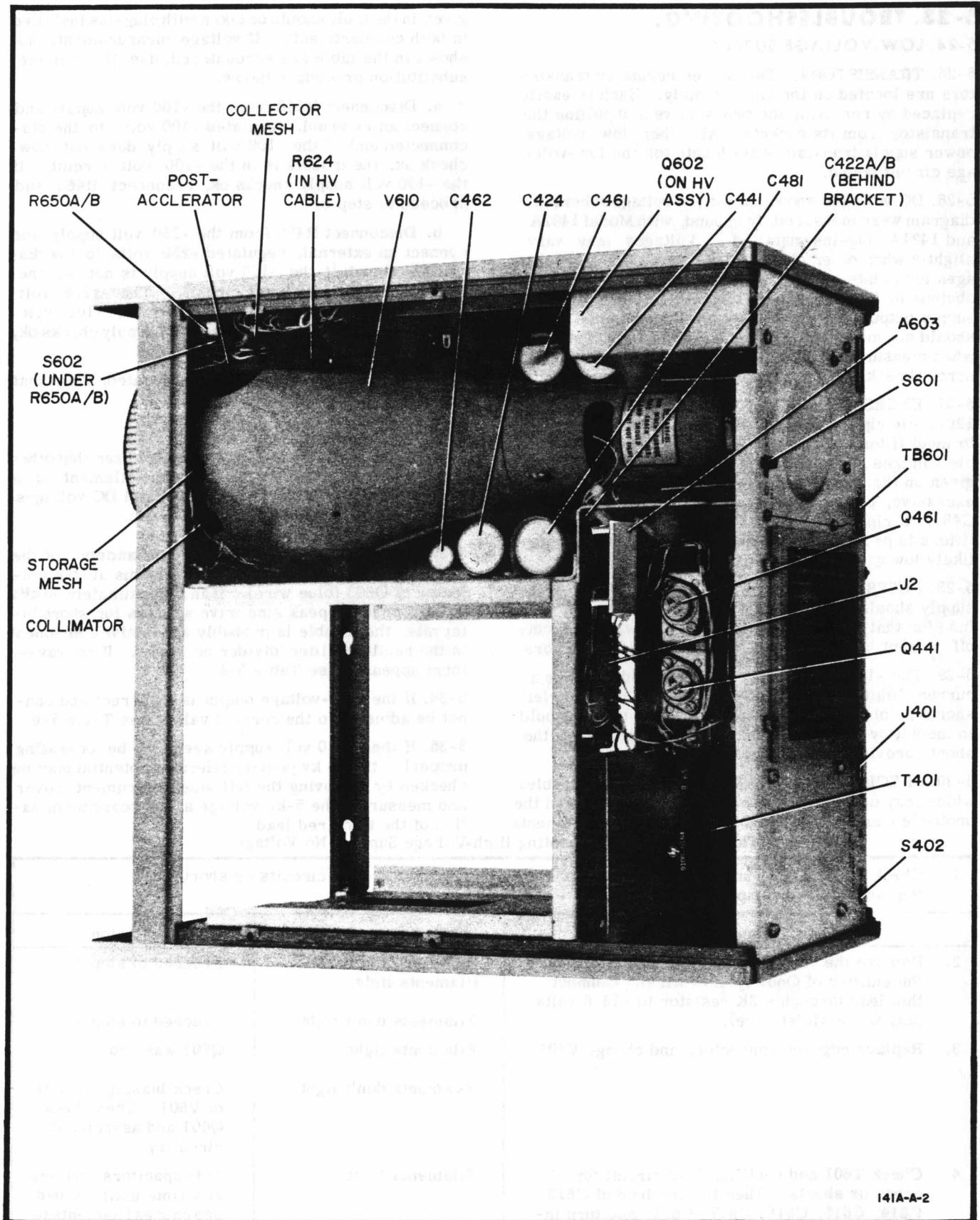

Figure 5-2. Component Locations, Top View

5-23. TROUBLESHOOTING.

5-24. LOW-VOLTAGE SUPPLY.

5-25. TRANSISTORS. The series regulator transistors are located on the fan assembly. Each is easily replaced by removing the two screws and pulling the transistor from its sockets. All other low voltage power supply transistors are located on the low-voltage circuit board.

5-26. DC voltages shown on the low voltage schematic diagram were measured, to ground, with Model 1402A/ and 1421A plug-ins installed. Voltages may vary slightly when other plug-ins are used. Correct voltages for points not marked for voltage are generally obvious by being connected (directly or indirectly) to a supply output. Transistor base voltage in most cases should not measurably differ from emitter voltage when measured with respect to ground. Voltage drops across breakdown diodes are indicated on the schematic.

5-27. EXCESSIVE RIPPLE. The cause of excessive 120-cycle ripple on any of the supplies can be isolated to input filter or regulator circuits by comparing ripple voltages at the rectifier outputs with the values given on the schematic. If ripple at these points is excessive, check capacitors C421, C441, C461, or C481. If ripple is high and is 60 Hz, one of the rectifiers is probably open. If normal, the cause is most likely low gain in the amplifier transistors.

5-28. FUSES. If the -12.6, -100, +100 or +250 volts supply should be accidentally shorted to ground, the fuse for that particular supply will blow. This cuts off current in the supply and protects the transistors.

5-29. The -12.6 volt supply is fused, and employs a current limiter, Q483, for protection against brief shortings of the output to ground. The supply should immediately function normally upon removal of the short, provided the fuse has not blown.

5-30. SPECIFIC TROUBLES. Table 5-5 lists troubles which may occur in the low voltage supplies and the probable cause of each trouble. Voltage measurements

Table 5-4. Troubleshooting High-Voltage Supply, No Voltage

Procedure	Indication	Conclusion
1. Check Q602, L601, and the associated transformer primary for open circuits or shorts. Replace any bad components.		
2. Remove the edge-on connector which goes to the emitter of Q601 (yellow wire). Connect this lead through a 2K resistor to -12.6 volts (any white-violet wire).	Rectifier (V602-V605) filaments light.	Proceed to step 3.
	Filaments don't light.	Proceed to step 4.
3. Replace edge-on connector, and change V601.	Filaments light.	Q601 was bad.
	Filaments don't light.	Check biasing circuitry of V601. Then check Q601 and associated circuitry.
4. Check T601 and rectifier load circuit for opens or shorts. Then lift one lead of C613, C614, C615, C616, C617, C621, and turn instrument on again.	Filaments light.	Put capacitors back one at a time until the bad one causes filaments to go out.
	Filaments don't light.	Trouble probably with transformer T601.

given in the table should be taken with plug-ins installed in both compartments. If voltage measurements not shown in the table are encountered, use the voltage substitution procedure below.

a. Disconnect R468 from the +100 volt supply and connect an external, regulated +100 volts to the disconnected end; if the -100 volt supply does not now check ok, the trouble is in the -100 volt circuit; if the -100 volt supply checks ok, reconnect R468 and proceed to step b.

b. Disconnect R450 from the +250 volt supply and connect an external, regulated +250 volts to the disconnected end; if the +100 volt supply is not ok, the trouble is in the +100 volt circuit. The -12.6 volt supply will also show defective when the +100 volt supply is defective. If the +100 volt supply checks ok, the trouble is in the +250 volt supply.

c. When the defective supply is located, check that circuit for defective components.

5-31. HIGH-VOLTAGE SUPPLY.

5-32. If one high-voltage supply output is zero but other outputs are normal, look for the unlit filament of a bad rectifier (V602 thru V605). Normal DC voltages are given on the high voltage schematic.

5-33. If there is no high-voltage output and none of the filaments are lit, observe the waveforms at the collector of Q603 (blue wire). If an approximately 30 kHz 20-volt peak-to-peak sine wave appears for short intervals, the trouble is probably a defective component in the rectifier filter/divider networks. If no waveform appears, use Table 5-4.

5-34. If the high-voltage output is incorrect and cannot be adjusted to the correct value, use Table 5-6.

5-35. If the -2350 volt supply seems to be operating properly, the +5 kv post-accelerator potential may be checked by removing the left side instrument cover and measuring the 5-kv voltage at the board termination of the thick red lead.

Table 5-5. Troubleshooting the Low-Voltage Supply

SUPPLY SYMPTOM				PROBABLE CAUSE OF TROUBLE
-12.6	-100	+100	+250	
	No current limiting			Q483 open (B - E short)
	Q421 not protected			CR425 open
ok	ok	119	280	Q444 open (B - E short)
ok	ok	117	282	Q443 short (B - E - C)
ok	ok	111	194	Q423 open (B - E short)
ok	ok	110	200	CR426 short
ok	ok	106	218	CR425 short
ok	ok	ok	198	Q422 open (removed)
ok	ok	96	274	Q421 open (green lead open)
ok	ok	94	292	CR426 open
ok	ok	93	295	CR445 open (cause Q421 short)
ok	ok	93	294	Q421 short (E - C)
ok	ok	93	286	Q422 short (E - C)
ok	ok	92	295	Q423 short (E - C)
ok	ok	81	55	Q421 open (removed)
ok	ok	80	55	F421 open
ok	ok	75	200	Q442 open (B - E short)
ok	ok	28	114	Q441 open (base disconnected)
22	ok	ok	ok	Q481 short (C - E causes Q484 B - E short)
22	ok	ok	ok	Q482 short (C - E causes Q484 to fail)
22	ok	ok	ok	Q484 open (removed)
0	ok	ok	ok	Q482 open (removed)
0	ok	ok	ok	Q482 short (B - E)
0	ok	ok	ok	Q481 open (base lead open)
0	ok	ok	ok	Q483 short (C - E)
0	ok	ok	ok	Q484 short (C - E)
18	142	144	344	Q461 short (C - E)
17	136	135	335	Q462 short (C - E)
0	0	0	0	Q464 open (E - B short blows F461)
14	113	145	342	Q441 short (C - E)
14	110	140	327	Q443 open (B - E short)
9	69	75	184	Q462 open (B - E short)
0	0	0	0	Q463 short (B - E blows F461)
5	63	77	185	Q463 short (C - E)
4	29	75	167	+100v removed from -100v supply
1	12	75	163	Q461 open (base lead open)
0	60	77	168	Q461 open (removed)

Table 5-6. Troubleshooting High-Voltage Supply, Incorrect Voltage

Procedure	Effect	Conclusion
1. Remove Nuvistor V601 from its socket.	Output drops to zero.	Proceed to step 2.
	Output remains at an incorrect value.	Q601 shorted.
2. Replace V601 in its socket, and lift one end of R601.	Output drops.	Trouble probably in the resistor divider network R611, R619 - R634.
	Output remains at an incorrect value.	V601 bad.

5-36. PULSE CIRCUIT.

5-37. A good knowledge of the operating procedures and an understanding of the principles of operation of the Model 141A are helpful when troubleshooting the pulse circuit. Refer to Section III for operating procedures and Section IV for principles of operation. Always use the turn-on procedure given in Paragraph 5-4 if the Model 141A is not operating properly.

5-38. All dc voltages from the low-voltage supply are used in the pulse circuit. When a malfunction occurs, check all voltages connected to the pulse circuit board. If all low voltages are ok, check the high voltages at the high-voltage circuit board. These checks will, by elimination, isolate the trouble to one general circuit. If both supplies are ok, check the waveforms at test points shown on the schematic diagram, Figure 5-9. Check dc voltages to isolate defective components in a stage where an improper, or no waveform is present. Conditions for measurements and waveforms for test points are given in Figure 5-10. The PERSISTENCE control should vary the pulse width of the waveforms observed at test points 4 through 8. With PERSISTENCE just out of NORMAL detent, Presentation Selector in WRITE, and no pulse present at test point 8, persistence will be maximum; this indicates a trouble in the multivibrator or pulse generator circuit. When a normal pulse, which is not variable, is present at test point 8, persistence is minimum; this indicates a malfunction in the PERSISTENCE control or Presentation Selector.

5-39. The pulse amplifier circuit functions only in the STORE position of the Presentation Selector. In all other positions, a steady dc voltage is applied to the collimator. If all modes, except STORE, operate properly, check waveforms 9, 10, and 11 in the pulse amplifier circuit.

5-40. PERIODIC MAINTENANCE.

5-41. ELECTRICAL MAINTENANCE.

5-42. Perform the electrical adjustments once every 6 months and after repair or component replacement.

5-43. MECHANICAL MAINTENANCE.

5-44. Inspect the air filter at the rear of the instrument and clean it before it becomes clogged and restricts air flow. To clean the filter, wash it thoroughly in warm water and detergent. Dry the filter thoroughly before installing it on the instrument. Oil the motor (one point) with light machine oil, once every 6 months.

5-45. INSTRUMENT REPAIR.

5-46. All components in the Model 141A are identified by reference designation in Figures 5-1 through 5-6, and 5-9. Components mounted on circuit boards are shown in the shaded area of the schematic diagrams, Figures 5-7, 5-8 and 5-11. Components not shown in the shaded areas are on the front panel, chassis, or switches of the instrument.

5-47. Figure 6-1 is an exploded view drawing of the Model 141A frame. All parts are identified by description and hp part number.

5-48. MAJOR COMPONENT REPAIR.

5-49. CRT REMOVAL AND REPLACEMENT. To remove the CRT, proceed as follows:

WARNING

To prevent personal injury, always wear a face mask or goggles and gloves when handling the CRT. Handle the CRT carefully.

- a. Remove top cover of instrument. (Top view drawing of Model 141A shown on inside of top cover.)
- b. Disconnect the clip-on leads from the bulb of the CRT.
- c. Disconnect the clip-on leads from the neck of the CRT.
- d. Remove the CRT bezel from the front panel of the instrument.
- e. Loosen the clamp at the CRT socket.
- f. Remove the socket from the CRT base; pry loose carefully.
- g. Place one hand on the CRT face and, with the other hand, slide the CRT forward and out of the instrument.
- h. To replace the CRT, reverse the procedure; check that all bulb and neck leads are connected before turning POWER ON.
- i. Check the trace alignment and geometry adjustments, Paragraphs 3-7 and 5-16 respectively.

5-50. FAN REMOVAL AND REPLACEMENT. Use the following procedure for removing, and reverse the procedure for replacing the cooling fan.

- a. Remove the top and bottom covers of the Model 141A.

- b. Disconnect the white-gray and white-green-gray wires from the fan terminals.
- c. Remove all transistor heat sinks from the fan assembly and push them out of the way.
- d. Remove the four fan mounting nuts on the rear panel of the instrument.
- e. Lift out the fan assembly.

5-51. HV DECK REMOVAL AND REPLACEMENT.
Most of the components on the high voltage deck can be replaced without removing the assembly. Other components can be removed and replaced by moving the deck part way out (without disconnecting wires). Refer to Figure 5-3 for mounting screws and wire identification; use the following procedure for removing the high voltage deck.

- a. Remove the left side and top covers.
- b. Disconnect the 6 wires from the board and remove the 4 mounting screws; see Figure 5-3 for wire and screw identification.
- c. Disconnect the post-accelerator lead from the CRT.
- d. Push the wires aside, tilt the deck away from the left side of the instrument and lift it out.

5-52. SERVICING CIRCUIT BOARDS.

5-53. The Model 141A has circuit boards of the plated through type. When servicing this type board, components can be removed and replaced by applying a soldering iron tip to the component connection on either side of the board. When removing a component with multiple leads, such as potentiometers, move the soldering iron tip from lead to lead while applying moderate pressure to the component to lift it from the board. Excess solder can be removed by applying heat and rotating a wooden toothpick in the hole. Hewlett-Packard Service Note M-20D contains additional information on the repair of circuit boards; important considerations are as follows:

- a. Do not apply excessive heat.
- b. Apply heat to component leads and remove component with a straight pull away from the board.
- c. Do not force replacement component leads into the hole.

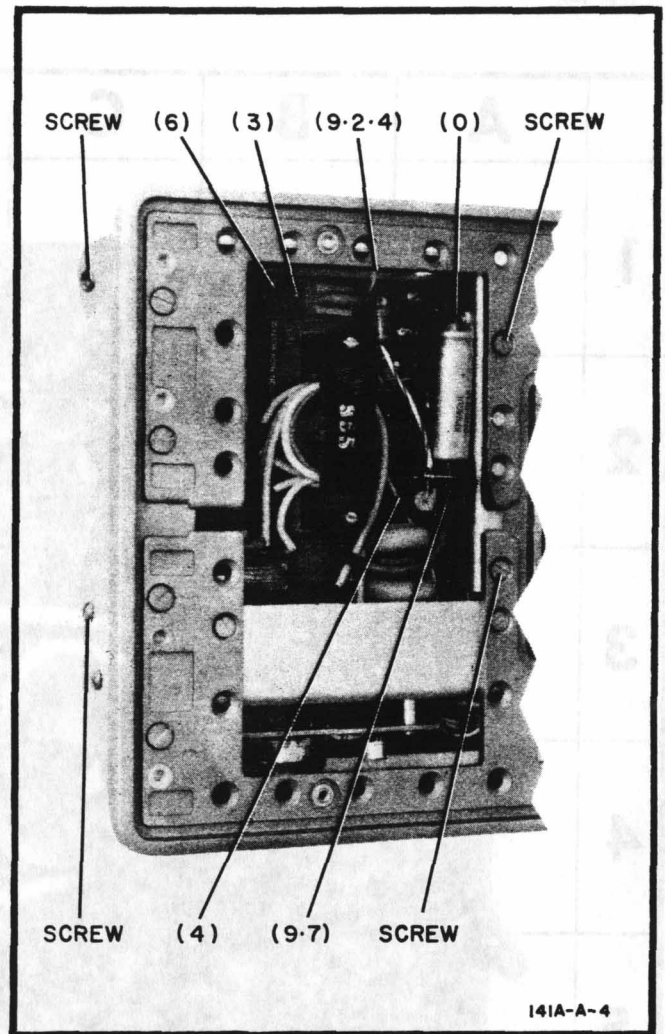

Figure 5-3. High Voltage Deck Removal

5-54. If the metal conductor lifts from the board, it can be cemented back with a quick-drying acetate base cement having good insulating properties. If the metal conductor is broken, solder a good conducting bare wire to the conductor so it bridges the break.

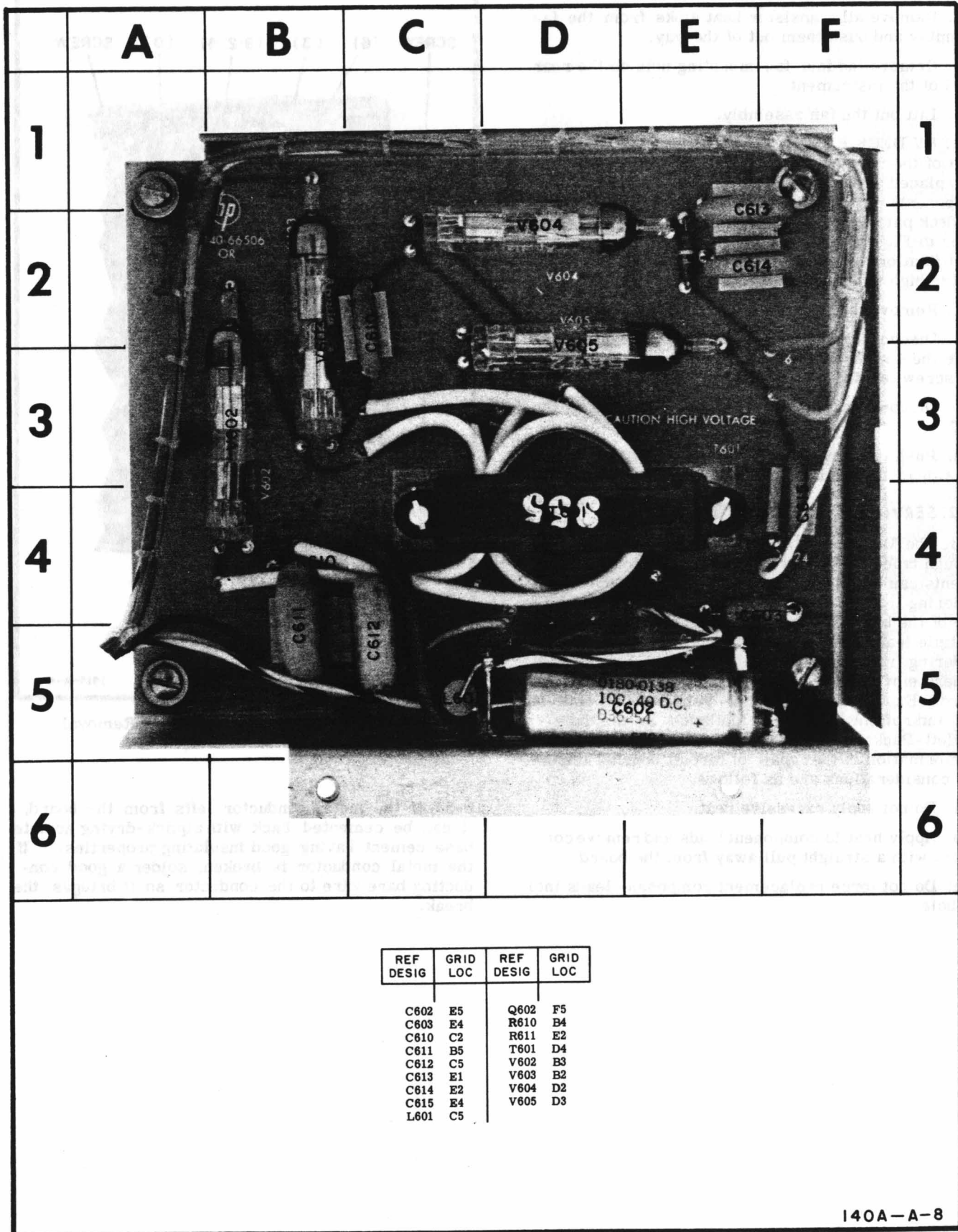

Figure 5-4. High-Voltage Deck Board

Table 5-7. Schematic Diagram Notes

Conditions for DC Voltage Measurement

DC Voltages shown on the schematic diagrams were measured, to ground, using a vacuum tube Voltmeter with a Model 1421A and a Model 1402A installed. Voltages shown are typical, $\pm 10\%$.

Refer to MIL-STD-15-1 for schematic symbols not listed in this table.

Unless otherwise indicated:
capacitance in picofarads
inductance in microhenries
resistance in ohms

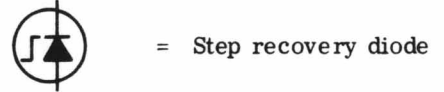
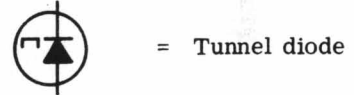
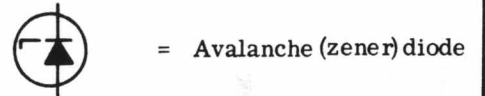
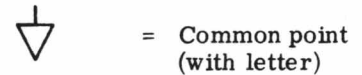
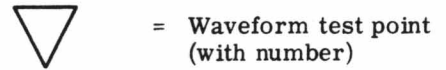
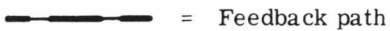
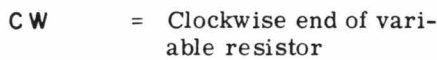
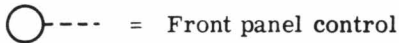
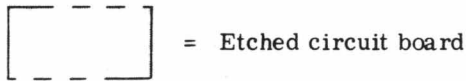

Numbers in parentheses indicate wire color using resistor color code, e.g. WHT-RED-GRN is (9-2-5).

- | | |
|------------|------------|
| 0 - Black | 5 - Green |
| 1 - Brown | 6 - Blue |
| 2 - Red | 7 - Violet |
| 3 - Orange | 8 - Gray |
| 4 - Yellow | 9 - White |

P/O = Part of

* = Optimum value selected at factory, average value shown; part may have been omitted.

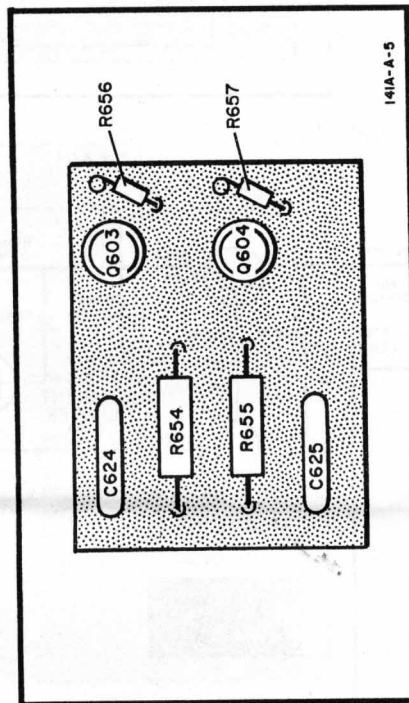
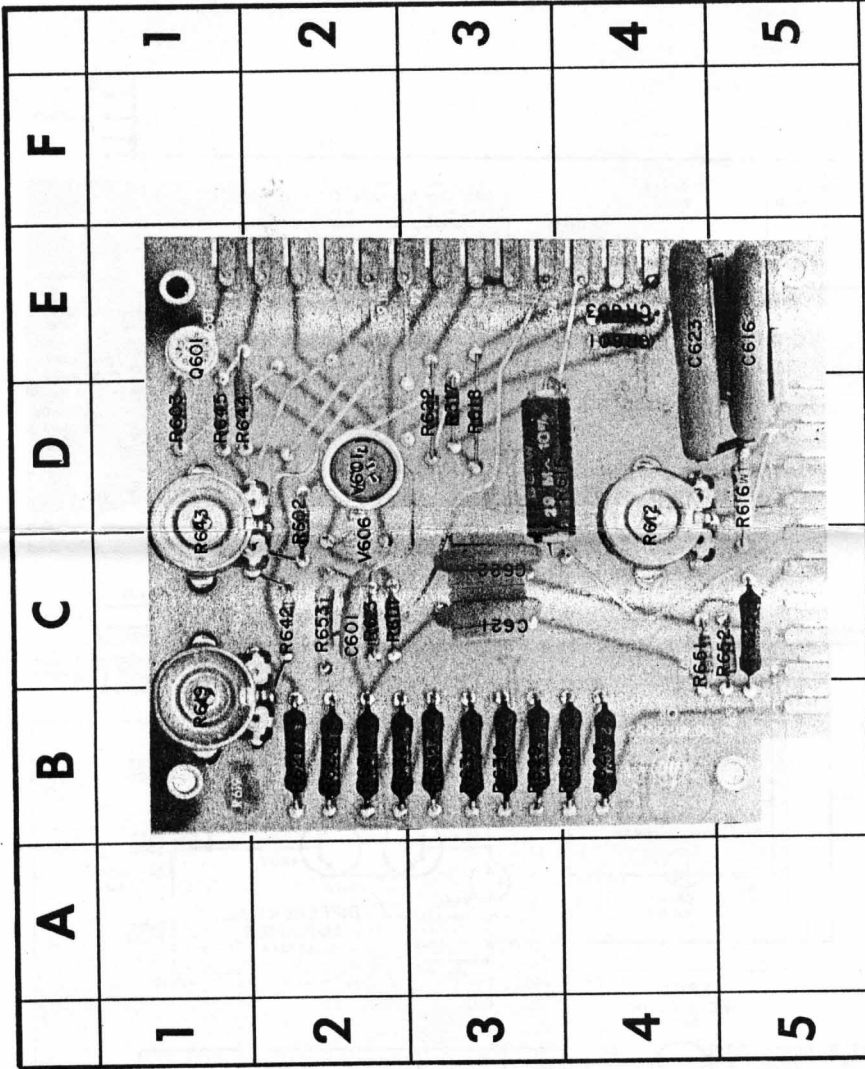
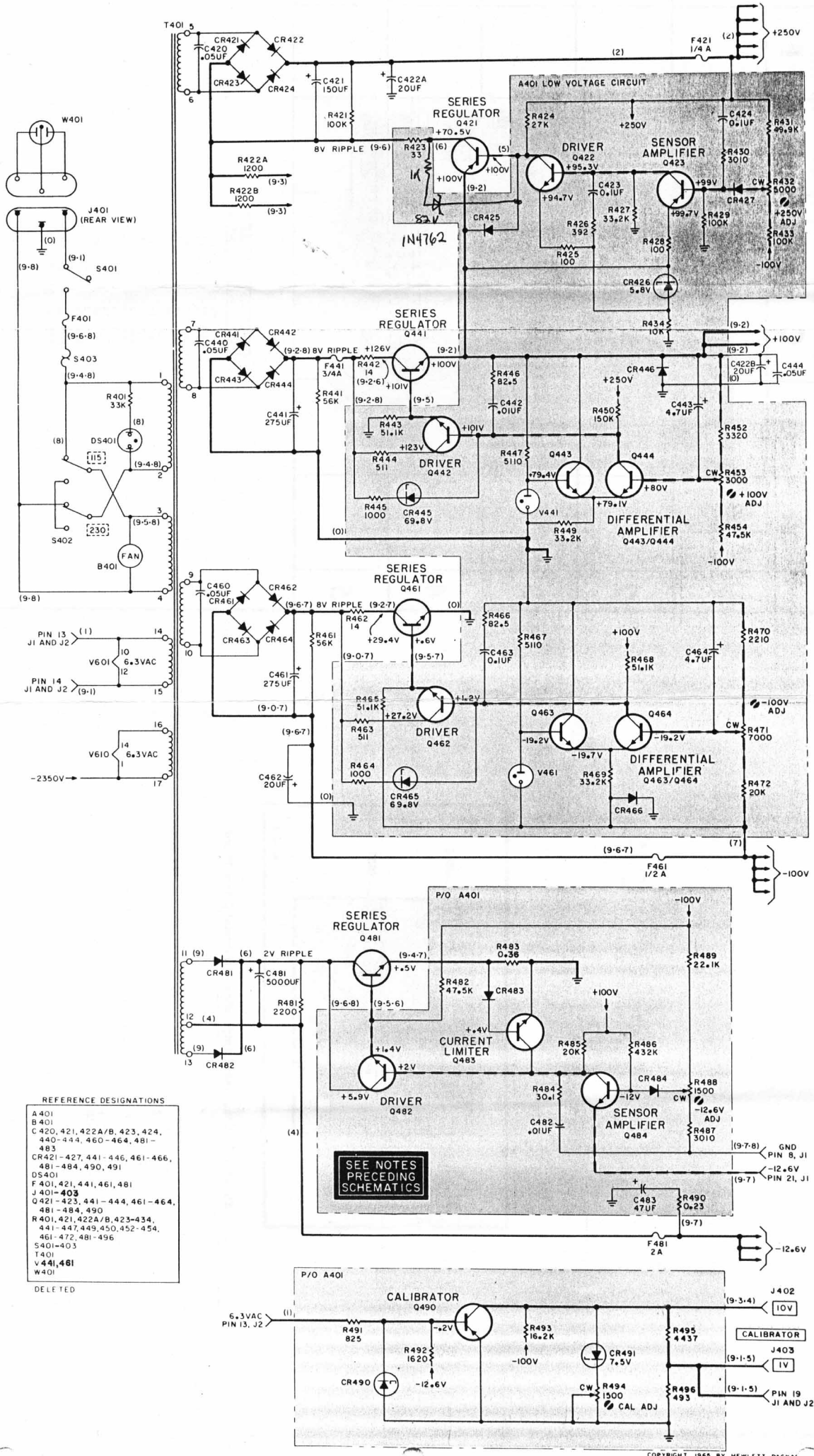

Figure 5-5. Component Identification, Horizontal Driver Board



REF DESIG	GRID LOC	REF DESIG	GRID LOC
C601	C2	R622	D3
C616	E5	R625	C5
C621	C3	R627	B4
C622	C3	R628	B4
C623	E4	R629	B3
CR601	E4	R630	B3
CR603	E4	R631	B3
Q601	E1	R632	B2
Q602	E1	R633	B2
Q603	E1	R634	B2
Q604	E1	R642	C2
Q605	E1	R643	C1
Q606	E1	R644	D1
Q607	E1	R645	D1
Q608	E1	R651	C4
Q609	E1	R652	C5
Q610	E1	R653	C2
Q611	E1	V601	D2
Q612	E1	V606	C2
Q613	E1		
Q614	E1		
Q615	E1		
Q616	E1		

Figure 5-6. Component Identification High-Voltage Board



REFERENCE DESIGNATIONS

A401
B401
C420, 421, 422A/B, 423, 424, 440-444, 460-464, 481-483
CR421-427, 441-446, 461-466, 481-484, 490, 491
DS401
F401, 421, 441, 461, 481
J401-403
Q421-423, 441-444, 461-464, 481-484, 490
R401, 421, 422A/B, 423-434, 441-447, 449, 450, 452-454, 461-472, 481-496
S401-403
T401
V441, 461
W401

DELETED

SEE NOTES PRECEDING SCHEMATICS

Figure 5-7. Low-Voltage Schematic Diagram
5-14

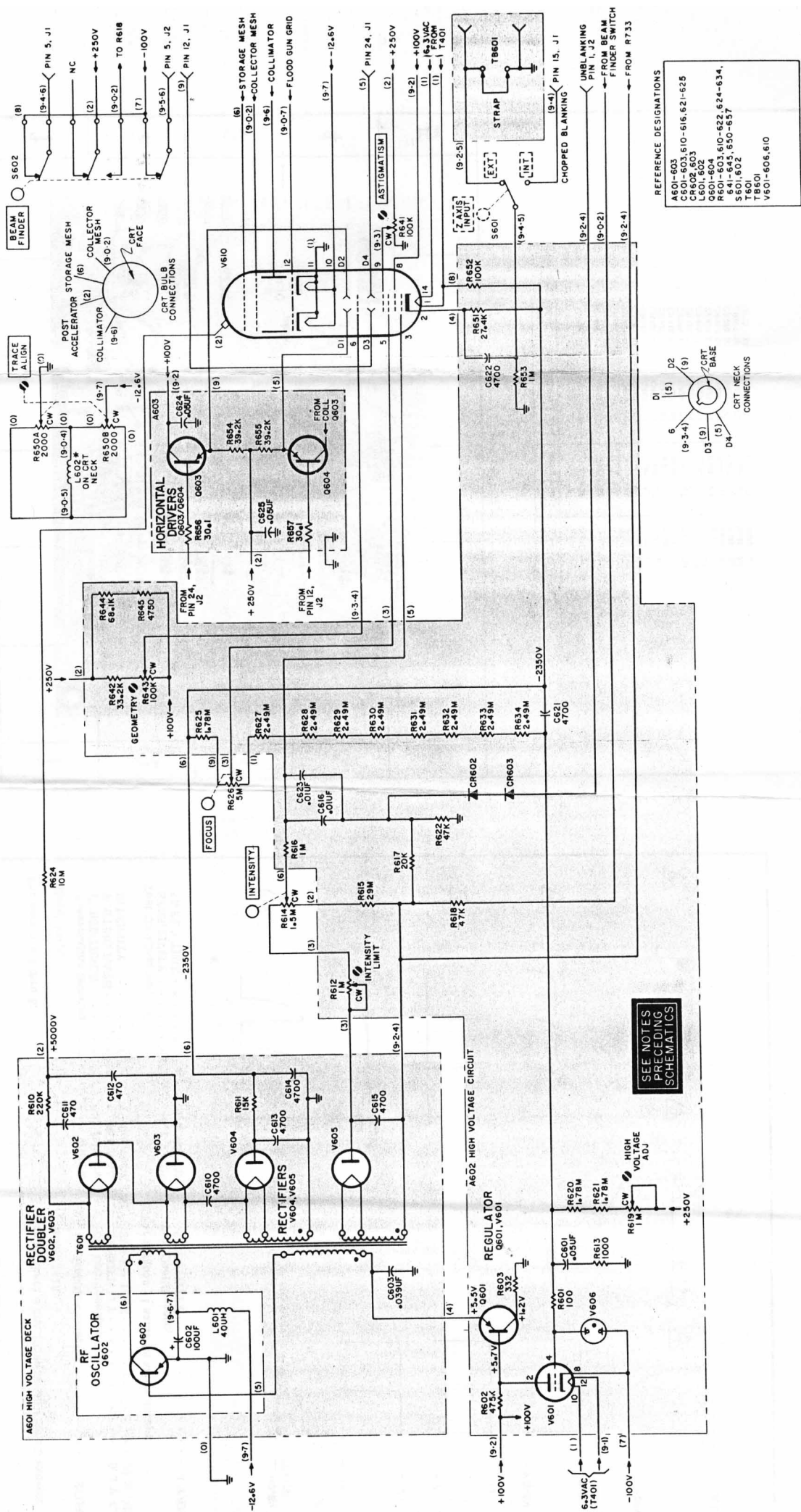
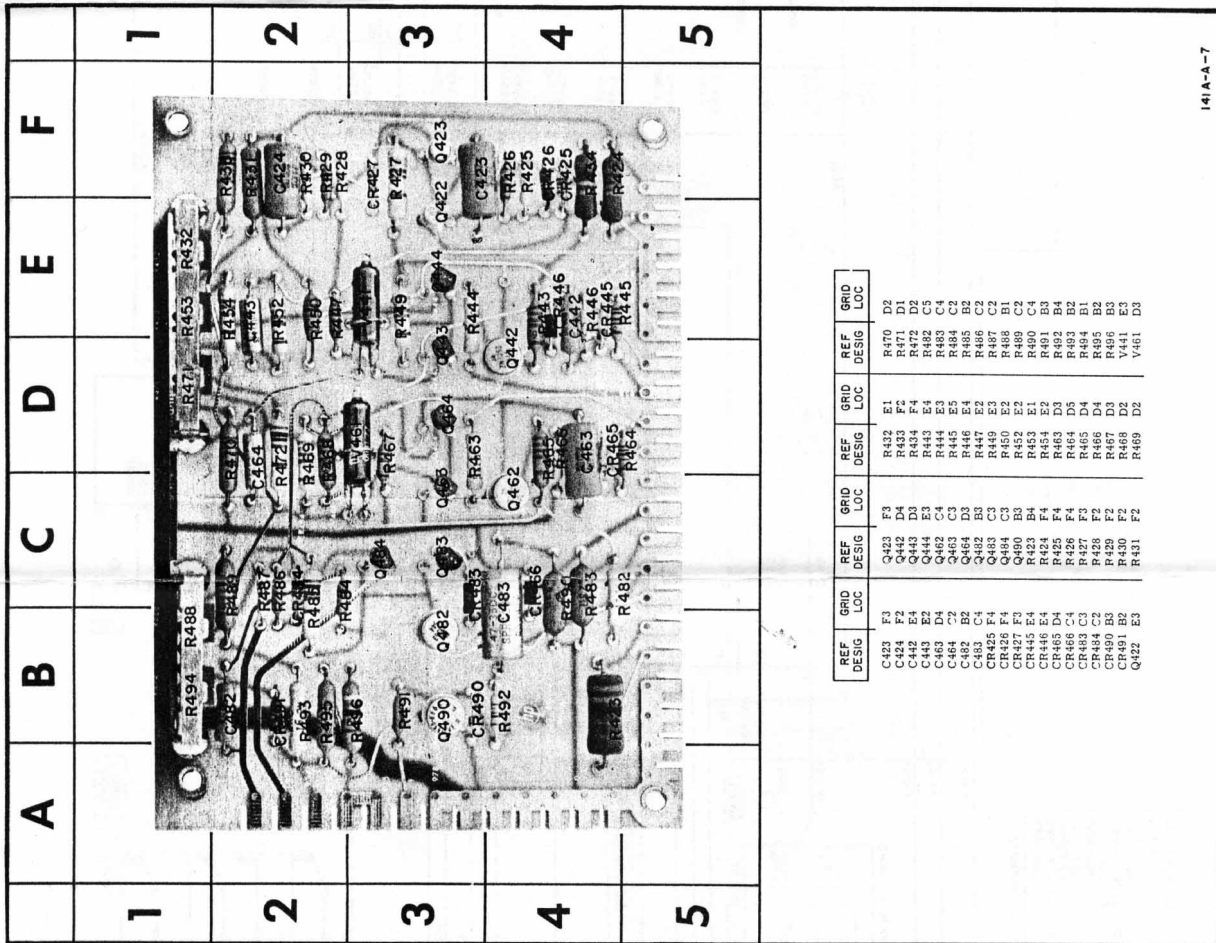

Figure 5-8. High-Voltage Schematic Diagram
5-15

Section V
Figures 5-9 and 5-10



141A-4-7

CONDITIONS FOR WAVEFORM MEASUREMENT

For numbers 1 thru 8:

Model 141A;
Presentation Selector WRITE
PERSISTENCE fully cw
WRITING RATE NORMAL
INTENSITY fully cw

For numbers 9 and 10; same as 1 thru 8 except:
Model 141A;

Presentation Selector STORE
Test Oscilloscope;
SENSITIVITY 0.1 V/CM
SWEEP TIME 20 μ S/CM

For number 11 same as above except:

Test Oscilloscope;
SENSITIVITY 1 V/CM
SWEEP TIME 0.2 MS/CM

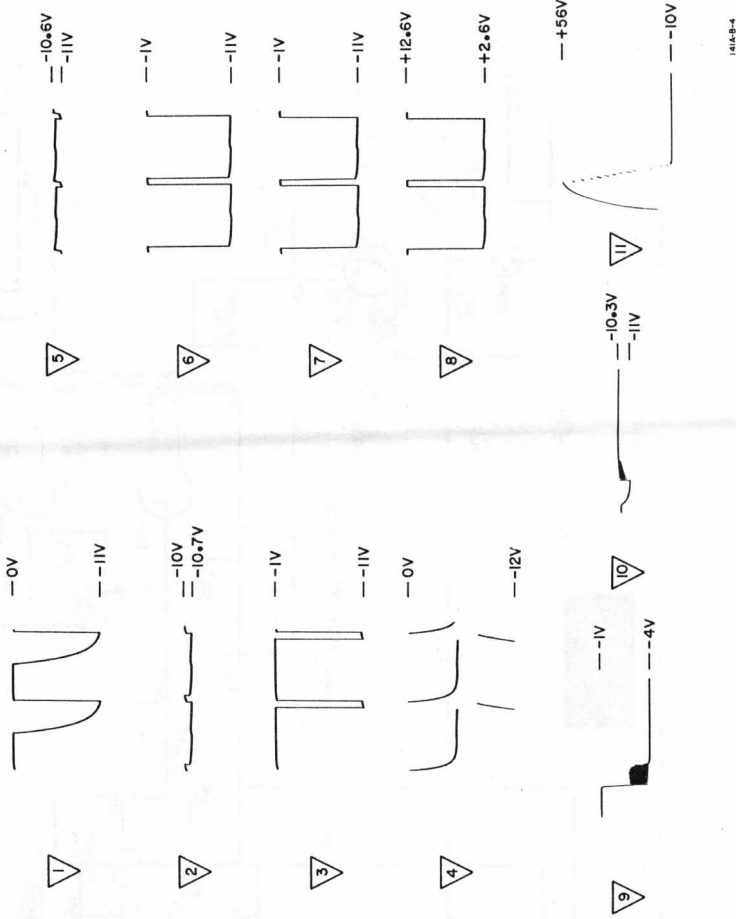
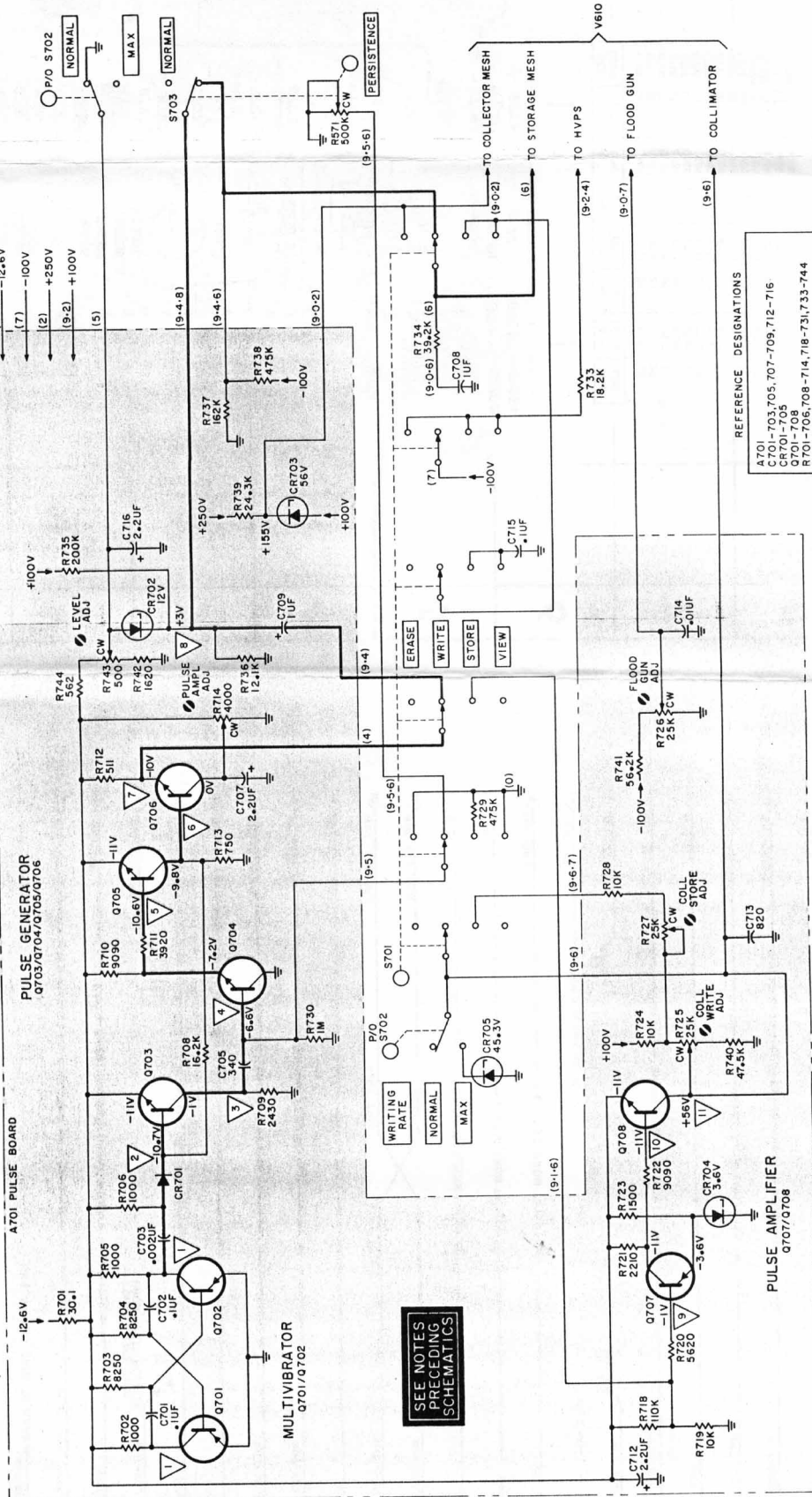

Figure 5-10. Waveforms

Figure 5-9. Component Identification, Low-Voltage Board



COPYRIGHT 1965 BY HEWLETT-PACKARD CO
14A-PULSE-CP1-341

Figure 5-11. Pulse Circuit Schematic Diagram
5-17

Section V
 Figures 5-12 and 5-13

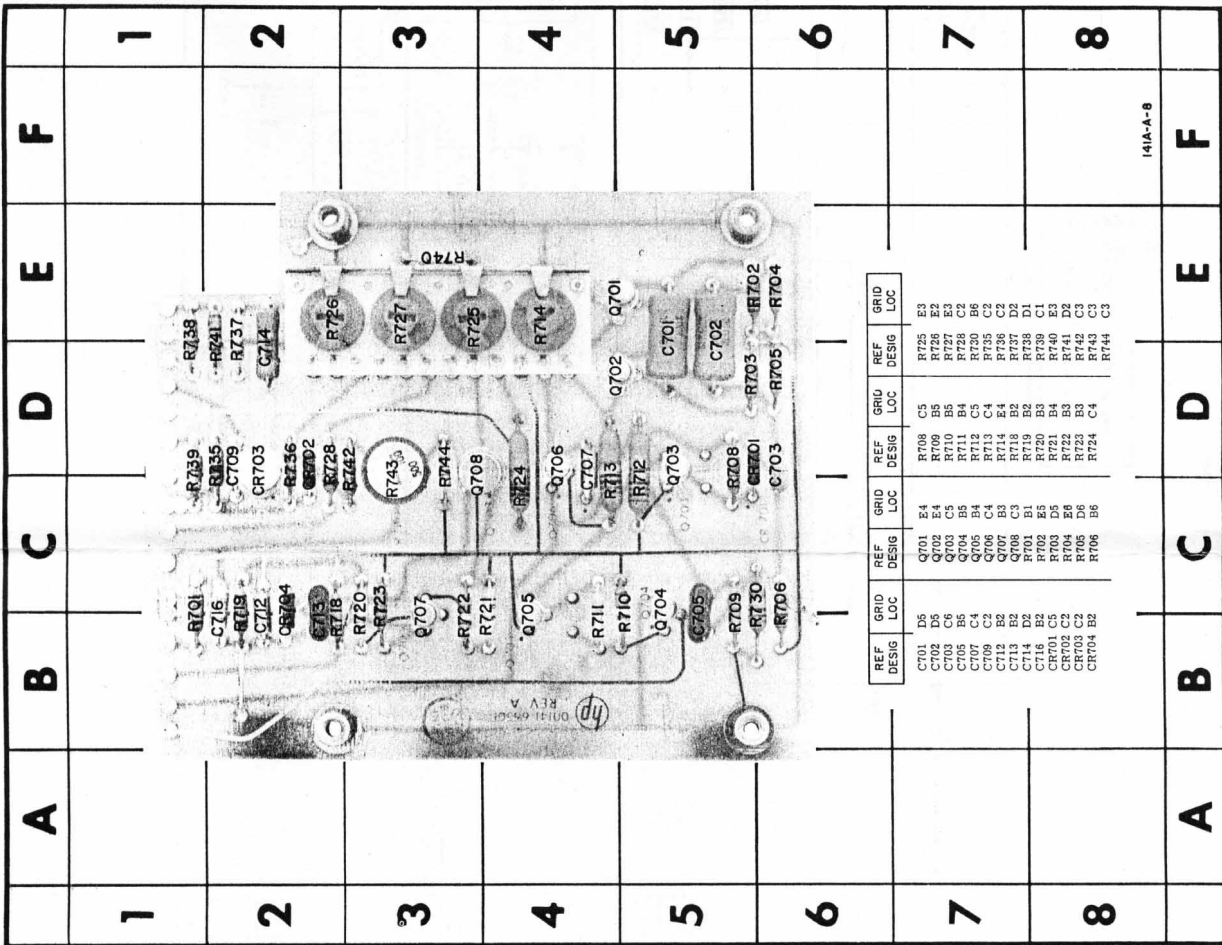

Figure 5-12. Component Identification, Pulse Circuit

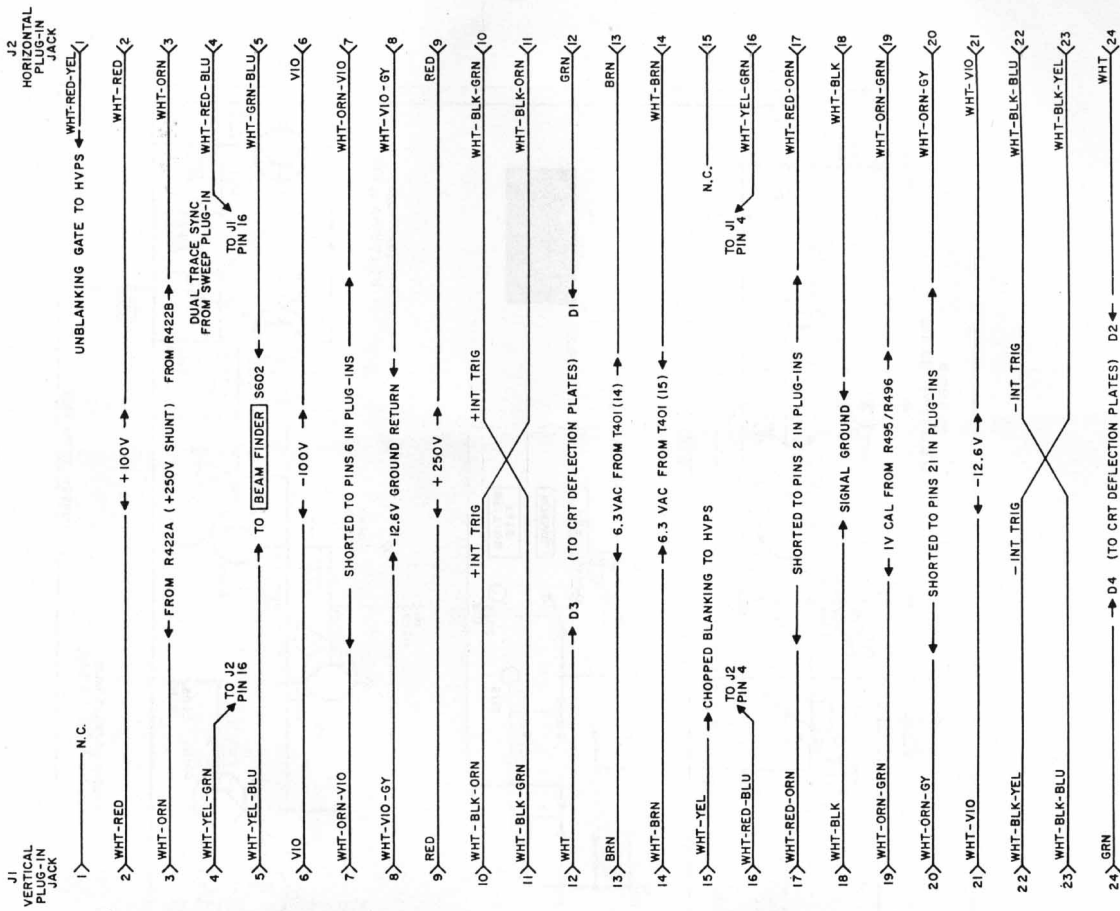

Figure 5-13. Plug-In Jack Connection

SECTION VI REPLACEABLE PARTS

6-1. INTRODUCTION.

6-2. This section contains information for ordering replaceable parts for the instrument. Table 6-2 lists the parts in alpha-numerical order of their reference designations and provides the following information for each item:

- a. hp Part Number.
- b. Total quantity (TQ) used in instrument; given only first time a part number is listed.
- c. Description of part; see Table 6-1 for list of reference designators and abbreviations.
- d. Typical manufacturer of part in a five-digit code, except for Hewlett-Packard Company; see code list of manufacturers, Table 6-3, for name.
- e. Manufacturer's part number.

6-3. Parts not identified by a reference designation are listed at the end of Table 6-2, under miscellaneous. Cabinet parts and the rack-mounting kit for the instrument are shown in Figure 6-1 and are identified by part number.

6-4. ORDERING INFORMATION.

6-5. To order a replacement part from the Hewlett-Packard Company, address the order or inquiry to the nearest Hewlett-Packard Sales/Service Office (list in rear of manual) and supply the following information:

- a. hp Part Number of item(s).
- b. Model number and eight-digit serial number of instrument.

6-6. To order a part not listed in the table, provide the following information:

- a. Model number and eight-digit serial number of instrument.
- b. Description of part including function and location.

6-7. To order a part from a manufacturer other than the Hewlett-Packard Company, provide the complete part description and the manufacturer's part number from the table.

Table 6-1. List of Reference Designators and Abbreviations

REFERENCE DESIGNATORS			
A = assembly B = motor C = capacitor CP = coupling CR = diode DL = delay line DS = device signaling (lamp)	E = misc electronic part F = fuse FL = filter J = jack K = relay L = inductor M = meter	MP = mechanical part P = plug Q = transistor R = resistor RT = thermistor S = switch T = transformer	TB = terminal board TP = test point V = vacuum tube, neon bulb, photocell, etc. W = cable X = socket Y = crystal
ABBREVIATIONS			
A = amperes A.F.C = automatic frequency control AMPL = amplifier B.F.O. = beat frequency oscillator BE CU = beryllium copper BH = binder head BP = bandpass BRS = brass BWO = backward wave oscillator CCW = counter-clockwise CER = ceramic CMO = cabinet mount only COEF = coefficient COM = common COMP = composition CONN = connector CP = cadmium plate CRT = cathode-ray tube CW = clockwise DEPC = deposited carbon DR = drive ELECT = electrolytic ENCAP = encapsulated EXT = external F = farads FH = flat head FIL H = fillister head FXD = fixed	GE = germanium GL = glass GRD = ground(ed) H = henries HEX = hexagonal HG = mercury HR = hour(s) IF = intermediate freq IMPG = impregnated INCD = incandescent INCL = include(s) INS = insulation(ed) INT = internal K = kilo = 1000 LIN = linear taper LK WASH = lock washer LOG = logarithmic taper LPF = low pass filter M = milli = 10 ⁻³ MEG = meg = 10 ⁶ METFLM = metal film MFR = manufacturer MINAT = miniature MOM = momentary MTG = mounting MY = "mylar" N = nano (10 ⁻⁹)	N/C = normally closed NE = neon NI PL = nickel plate N/O = normally open NPO = negative positive zero (zero temperature coefficient) NRFR = not recommended for field replacement NSR = not separately replaceable OBD = order by description OH = oval head OX = oxide P = peak PC = printed circuit PF = picofarads = 10 ⁻¹² farads PH BRZ = phosphor bronze PHL = Phillips PIV = peak inverse voltage P/O = part of POLY = polystyrene PORC = porcelain POS = position(s) POT = potentiometer PP = peak-to-peak PT = point RECT = rectifier RF = radio frequency RH = round head	RMO = rack mount only RMS = root-mean-square S-B = slow-blow SCR = screw SE = selenium SECT = section(s) SEMICON = semiconductor SI = silicon SIL = silver SL = slide SPL = special SST = stainless steel SR = split ring STL = steel TA = tantalum TD = time delay TGL = toggle TI = titanium TOL = tolerance TRIM = trimmer TWT = traveling wave tube U = micro = 10 ⁻⁶ VAR = variable VDCW = dc working volts W/ = with W = watts WW = wirewound W/O = without

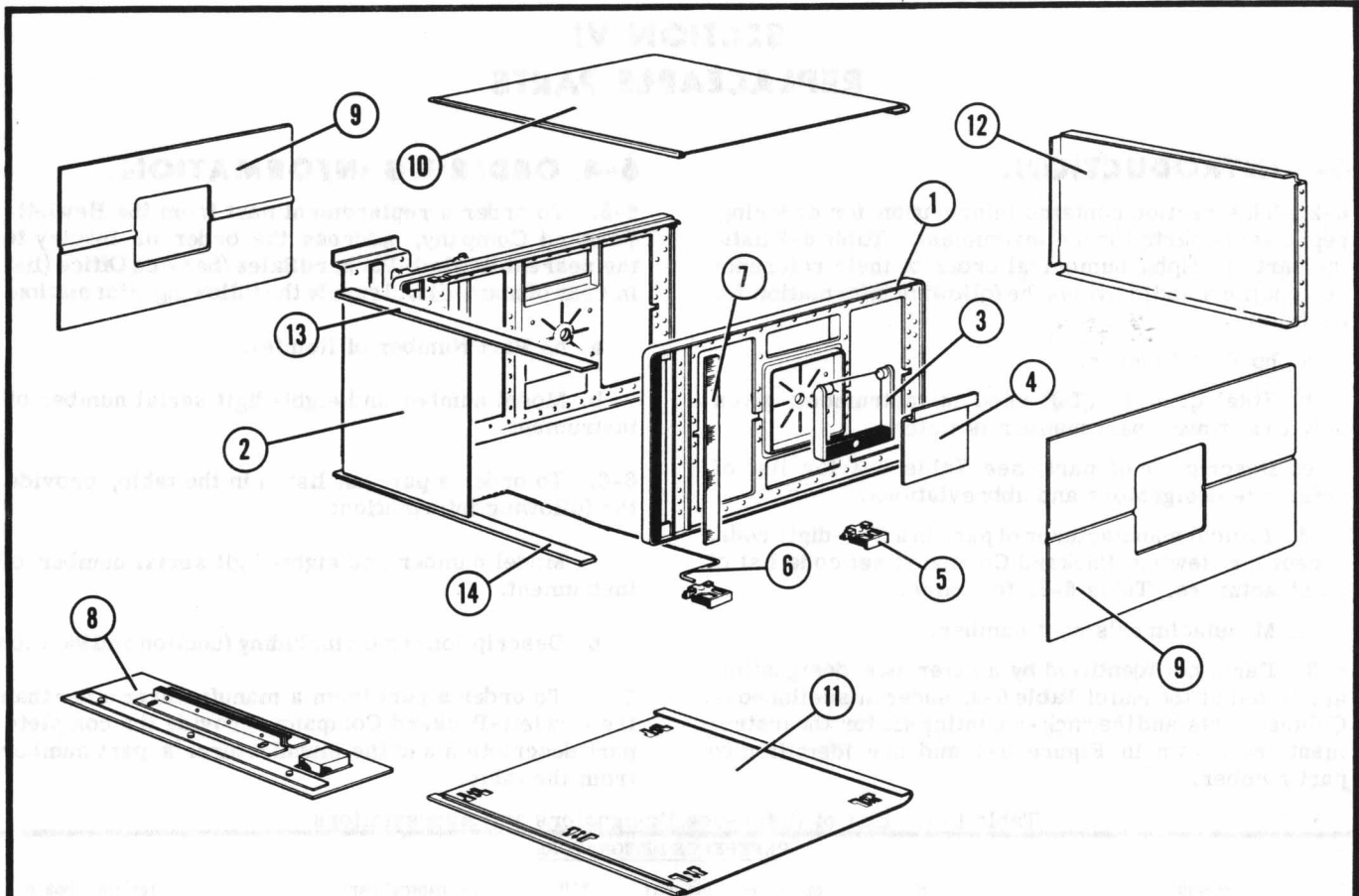

140A-B-3

Part	Part Number	Quantity
1. Frame Assembly	5060-0736	2
2. Front Panel	00140-00204	1
3. Side Handle Assembly	5060-0763	2
4. Handle Retainer	5060-0765	2
5. Foot Assembly	5060-0767	5
6. Tilt Stand	1490-0030	1
7. Plastic Trim	6980-0004	2
8. Rack Mount Kit	5060-0777	1
9. Side Cover	5000-0747	2
10. Top Cover Assembly	5060-0740	1
11. Bottom Cover Assembly	00140-04402	1
12. Rear Panel	00140-00202	1
13. Top Panel Support	00140-24701	1
14. Bottom Panel Support	00140-24702	1

Figure 6-1. Cabinet Parts, Exploded View

Table 6-2. Replaceable Parts

Ref Desig	hp Part No.	RS	TQ	Description (See Table 6-1.)	Mfr	Mfr Part No.
A2	00141-60401		1	A: hv deck	hp	
A3 -						
A400				Not assigned		
A401	00140-66504		1	A: low voltage supply board	hp	
A402	2100-1589		1	A: r var 3 sect 7k, 3k, 5k ohms 20%	hp	
A403	2100-1588		1	A: r var 2 sect 1.5k 30% (each)	hp	
A404 -						
A600				Not assigned		
A601	00140-66506		1	A: high voltage deck	hp	
A602	00140-66505		1	A: high voltage circuit	hp	
A603						
A604 -						
A700				Not Assigned		
A701	00141-66501		1	A: pulse generator	hp	
A702	00141-61901		1	A: mode switch	hp	
A703	2100-1441		1	A: r var car. comp type H 4 sect 3 x 25k ohms 30% 4k ohms 30% 1/4w (includes R714, R725, R726, R727)	hp	
B401	3160-0056		1	B: fan - tube axial	hp	
C420	0150-0052		7	C: fxd cer 0.05 μ f 20% 400vdcw	56289	33C17A
C421	0180-0147		1	C: fxd elect 150 μ f -10 +50% 250vdcw	00853	PLI
C422	0180-0012		1	C: fxd elect 2 x 20 μ f 450vdcw	56289	D32440
C423	0160-0168		3	C: fxd my 0.1 μ f 10%	hp	
C424	0160-0168			C: fxd my 0.1 μ f 10%	hp	
C425 -						
C439				Not assigned		
C440	0150-0052			C: fxd cer 0.05 μ f 20% 400vdcw	56289	33C17A
C441	0180-0214		2	C: fxd elect 275 μ f -10 +50% 200vdcw	56289	30D208G006DF4
C442	0160-0207		2	C: fxd my 0.01 μ f 5% 200vdcw	hp	
C443	0180-0100		2	C: fxd elect 4.7 μ f 10% 35vdcw	56289	150D475X9035B2
C444	0150-0052			C: fxd cer 0.05 μ f 20% 400vdcw	56289	33C17A
C445 -						
C459				Not assigned		
C460	0150-0052			C: fxd cer 0.05 μ f 20% 400vdcw	56289	33C17A
C461	0180-0214			C: fxd elect 275 μ f -10 +50% 200vdcw	56289	30208G006DF4
C462	0180-0093		1	C: fxd elect 20 μ f 150vdcw	56289	D33193
C463	0160-0168			C: fxd my 0.1 μ f 10%	hp	
C464	0180-0100			C: fxd elect 4.7 μ f 10% 35vdcw	56289	150D475X9035B2
C465 -						
C480				Not assigned		
C481	0180-0213		1	C: fxd elect 5000 μ f 25vdcw	00853	PLI
C482	0160-0207			C: fxd my 0.01 μ f 5% 200vdcw	hp	
C483	0180-0097		1	C: fxd elect 47 μ f 10% 35vdcw	56289	150D476X9035S
C484 -						
C600				Not assigned		
C601	0150-0052			C: fxd cer 0.05 μ f 20% 400vdcw	56289	33C17A
C602	0180-0138		1	C: fxd elect 100 μ f -10 +100% 40vdcw	56289	D36254
C603	0160-0164		1	C: fxd my .039 μ f 10%	hp	
C604 -						
C609				Not assigned		
C610	0160-0151		6	C: fxd cer 4700 pf -80 +20% 400vdcw	71590	DA172Z097CB

Table 6-2. Replaceable Parts (Cont'd)

Ref Desig	hp Part No.	RS	TQ	Description (See Table 6-1.)	Mfr	Mfr Part No.
C611	0150-0036		2	C: fxd cer 470 pf 20% 6kv	91418	S6KV470 20Z
C612	0150-0036		2	C: fxd cer 470 pf 20% 6kv	91418	S6KV470 20Z
C613	0160-0151			C: fxd cer 4700 pf -80 +20% 400vdcw	71590	DA172-097CB
C614	0160-0151			C: fxd cer 4700 pf -80 +20% 400vdcw	71590	DA172-097CB
C615	0160-0151			C: fxd cer 4700 pf -80 +20% 400vdcw	71590	DA172-097CB
C616	0160-0907		2	C: fxd cer 0.01 μ f -80 +20% 5000vdcw	hp	
C617 -						
C620				Not assigned		
C621	0160-0151			C: fxd cer 4700 pf -80 +20% 400vdcw	71590	DA172-097CB
C622	0160-0151			C: fxd cer 4700 pf -80 +20% 400vdcw	71590	DA172-097CB
C623	0160-0907			C: fxd cer 0.01 μ f -80 +20% 5000vdcw	hp	
C624	0150-0052			C: fxd cer 0.05 μ f 5% 200vdcw	hp	
C625	0150-0052			C: fxd cer 0.05 μ f 5% 200vdcw	hp	
C626 -						
C700				Not assigned		
C701	0160-0168			C: fxd my 0.1 μ f 10%	hp	
C702	0160-0168			C: fxd my 0.1 μ f 10%	hp	
C703	0150-0023		1	C: fxd cer 2000 pf 20% 1000vdcw	84411	Type 126
C704				Not assigned		
C705	0140-0227		1	C: fxd mica 340 pf 1% 300vdcw	04062	TDM15F341F3C
C706				Not assigned		
C707	0180-0155		3	C: fxd ta 2.2 μ f 20% 20vdcw	56289	150D225 0020AZ
C708	0170-0018		1	C: fxd my 1 μ f 5% 200vdcw	84411	Type 621M 10552
C709	0180-0230		1	C: fxd ta elect 1 μ f 20% 50vdcw	56289	150D105X0050 A2
C710 &						
C711				Not assigned		
C712	0180-0155			C: fxd ta 2.2 μ f 20% 20vdcw	56289	150D225 0020AZ
C713	0140-0151		1	C: fxd mica 820 pf 2% 300vdcw	04062	RDM15F821G3S
C714	0160-0207		1	C: fxd my 0.01 μ f 5% 200vdcw	hp	
C715	0150-0121		1	C: fxd cer 0.1 μ f -20 +80%	56289	5CMOA
C716	0180-0155			C: fxd ta 2.2 μ f 20% 20vdcw	56289	150D225 0020AZ
CR421	1901-0028		12	CR: si	hp	
CR422	1901-0028			CR: si	hp	
CR423	1901-0028			CR: si	hp	
CR424	1901-0028			CR: si	hp	
CR425	1910-0015		2	CR: ge	hp	
CR426	1902-0034		1	CR: 5.8v 10% 400mw	hp	
CR427	1901-0096		1	CR: si	hp	
CR428 -						
CR440				Not assigned		
CR441	1901-0028			CR: si	hp	
CR442	1901-0028			CR: si	hp	
CR443	1901-0028			CR: si	hp	
CR444	1901-0028			CR: si	hp	
CR445	1902-3385		2	CR: si 69.8v 5%	hp	
CR446	1901-0026		2	CR: si	hp	
CR447 -						
CR460				Not assigned		
CR461	1901-0028			CR: si	hp	
CR462	1901-0028			CR: si	hp	
CR463	1901-0028			CR: si	hp	

Table 6-2. Replaceable Parts (Cont'd)

Ref Desig	hp Part No.	RS	TQ	Description (See Table 6-1.)	Mfr	Mfr Part No.
CR464	1901-0028			CR: si	hp	
CR465	1902-3385			CR: si 69.8v 5%	hp	
CR466	1901-0026			CR: si	hp	
CR467 - CR480				Not assigned		
CR481	1901-0032		2	CR: rectifier si 15 amp	04713	1N3209
CR482	1901-0032			CR: rectifier si 15 amp	04713	1N3209
CR483	1901-0025		1	CR: si	hp	
CR484	1910-0015			CR: ge	hp	
CR485 - CR489				Not assigned		
CR490	1912-0006		1	CR: ge	hp	
CR491	1902-0064		1	CR: si	hp	
CR492 - CR601				Not assigned		
CR602	1901-0037		2	CR: si	81751	81 Z
CR603	1901-0037			CR: si	81751	81 Z
CR604 - CR700				Not assigned		
CR701	1901-0040		1	CR: si	hp	
CR702	1902-0031		1	CR: avalanche 12.7v 5%	hp	
CR703	1902-0214		1	CR: avalanche si 56.2v 10%	hp	
CR704	1902-0062		1	CR: avalanche 3.74v 10% 400mw	hp	
CR705	1902-0038		1	CR: avalanche 45.3v 5%	hp	
DS401	1450-0048		1	DS: neon	hp	
F401	2110-0014		1	F: cartridge 4 amp 125v slow	71400	MDXZ4
F402 - F420	2110-0006		1	F: cartridge 2 amp 125v slow	71400	MDL2
F421	2110-0004		1	Not assigned	75915	AG-CAT J 312J250
F422 - F440				Not assigned		
F441	2110-0033		1	F: 0.75 amp 250v	79515	F02GR750A
F442 - F460				Not assigned		
F461	2110-0012		1	F: cartridge 1/2 amp 250v	75915	312500
F462 - F480				Not assigned		
F481	2110-0003		1	F: cartridge 3 amp 3 AG	75915	312003
J1	1251-0054		2	J: 24 contact	hp	
J2	1251-0054			J: 24 contact	hp	
J3 - J400				Not assigned		
J401	1251-0148			J: power	hp	
J402	1250-0202		2	J: calibrator	83330	221B
J403	1251-0202			J: calibrator	83330	221B
L601	9140-0171		1	L: fxd 40 μ h 10% 1 amp	78526	HZ9897
L602	5060-0429		1	L: alignment	hp	
Q421	1850-0098		1	Q: ge pnp 1853-0252	hp	
Q422	1854-0005		1	Q: si npn	07263	2N708
Q423	1853-0009		1	Q: si pnp	hp	
Q424 - Q440				Not assigned		

Table 6-2. Replaceable Parts (Cont'd)

Ref Desig	hp Part No.	RS	TQ	Description (See Table 6-1.)	Mfr	Mfr Part No.
Q441	1854- 0084 ⁰²¹⁴		3	Q: si npn	07256	2N3232
Q442	1854-0090		2	Q: si npn	04713	SM8158
Q443	1854-0071		5	Q: si npn	89473	16A792
Q444	1854 0071			Q: si npn	89473	16A792
Q445 - Q460				Not assigned		
Q461	1854- 0084 ⁰²¹⁴			Q: si npn	07256	2N3232
Q462	1854-0090			Q: si npn	04713	SM8158
Q463	1854-0071			Q: si npn	89473	16A792
Q464	1854-0071			Q: si npn	89473	16A792
Q465 - Q480				Not assigned		
Q481	1854- 0084 ⁰²¹⁴			Q: si npn	07256	2N3232
Q482	1854-0039		1	Q: si 2N3053	02735	2N3053
Q483	1854-0083		1	Q: si npn	hp	
Q484	1854-0071			Q: si npn	89473	16A792
Q485 - Q489				Not assigned		
Q490	1850-0062		2	Q: ge pnp	hp	
Q491 - Q600				Not assigned		
Q601	1850-0062			Q: ge pnp	hp	
Q602	1850-0143		1	Q: ge spl	hp	
Q603	1853-0038			Q: si pnp	hp	
Q604	1853-0038			Q: si pnp	hp	
Q605 - Q700				Not assigned		
Q701	1853-0009		3	Q: si pnp	hp	
Q702	1853-0009			Q: si pnp	hp	
Q703	1854-0019		4	Q: si npn	hp	
Q704	1854-0019			Q: si npn	hp	
Q705	1854-0019			Q: si npn	hp	
Q706	1854-0019			Q: si npn	hp	
Q707	1853-0009			Q: si pnp	hp	
Q708	1854-0022		1	Q: si npn	hp	
R401	0687-3331		1	R: fxd comp 33k ohms 10% 1/2w	01121	EB 3331
R402 - R420				Not assigned		
R421	0687-1041		1	R: fxd comp 100k ohms 10% 1/2w	01121	EB 1041
R422A/B	0815-0031		1	R: fxd ww 2400 ohms 5%	35434	CHE10-2400
R423	0764-0033		1	R: fxd met ox 33 ohms 5% 2w	hp	
R424	0761-0007		1	R: fxd met ox 27k ohms 5% 1w	hp	
R425	0757-0401		2	R: fxd metflm 100 ohms 1% 1/8w	hp	
R426	0757-0413		1	R: fxd metflm 392 ohms 1% 1/8w	hp	
R427	0757-0044		1	R: fxd metflm 33.2k ohms 1% 1/2w	hp	
R428	0757-0401			R: fxd metflm 100 ohms 1% 1/8w	hp	
R429	0757-0465		1	R: fxd metflm 100k ohms 1% 1/8w	hp	
R430	0757-0273		2	R: fxd metflm 3.01k ohms 1% 1/8w	hp	
R431	0757-0370		1	R: fxd metflm 49.9k ohms 1% 1/2w	hp	
R432				NSR: p/o A402		

Table 6-2. Replaceable Parts (Cont'd)

Ref Desig	hp Part No.	RS	TQ	Description (See Table 6-1.)	Mfr	Mfr Part No.
R433	0757-0367		1	R: fxd metflm 100k ohms 1% 1/2w	hp	
R434	0761-0006		1	R: fxd metflm 10k ohms 5% 1w	hp	
R435 - R440				Not assigned		
R441	0687-5631		2	R: fxd comp 56k ohms 10% 1/2w	01121	EB 5631
R442	0816-0019		2	R: fxd ww 14 ohms 10w	hp	
R443	0757-0769		3	R: fxd metflm 51.1k ohms 1% 1/4w	hp	
R444	0757-0726		2	R: fxd metflm 511 ohms 1% 1/4w	hp	
R445	0757-0280		2	R: fxd metflm 1000 ohms 1% 1/8w	hp	
R446	0757-0399		2	R: fxd metflm 82.5 ohms 1% 1/8w	hp	
R447	0757-0438		2	R: fxd metflm 5.11k ohms 1% 1/8w	hp	
R448				Not assigned		
R449	0757-0764		2	R: fxd metflm 33.2k ohms 1% 1/4w	hp	
R450	0757-0779		1	R: fxd metflm 150k ohms 1% 1/4w	hp	
R451				Not assigned		
R452	0757-0193		1	R: fxd metflm 3.32k ohms 1% 1/2w	hp	
R453				NSR: p/o A402		
R454	0757-0852		1	R: fxd metflm 47.5k ohms 1% 1/2w	hp	
R455 - R460				Not assigned		
R461	0687-5631			R: fxd comp 56k ohms 10% 1/2w	01121	EB 5631
R462	0816-0019			R: fxd ww 14 ohms 10% 10w	hp	
R463	0757-0726			R: fxd metflm 511 ohms 1% 1/8w	hp	
R464	0757-0280			R: fxd metflm 1000 ohms 1% 1/8w	hp	
R465	0757-0769			R: fxd metflm 51.1k ohms 1% 1/4w	hp	
R466	0757-0399			R: fxd metflm 82.5 ohms 1% 1/8w	hp	
R467	0757-0438			R: fxd metflm 5.11k ohms 1% 1/8w	hp	
R468	0757-0769			R: fxd metflm 51.1k ohms 1% 1/4w	hp	
R469	0757-0764			R: fxd metflm 33.2k ohms 1% 1/4w	hp	
R470	0757-0825		1	R: fxd metflm 2.21k ohms 1% 1/2w	hp	
R471				NSR: p/o A402		
R472	0757-0190		2	R: fxd metflm 20k ohms 1% 1/2w	hp	
R473 - R480				Not assigned		
R481	0687-2221		1	R: fxd comp 2200 ohms 10% 1/2w	01121	EB 2221
R482	0757-0768		1	R: fxd metflm 47.5k ohms 1% 1/4w	hp	
R483	0811-1746		1	R: fxd ww 0.36 ohms 5% 2w	81483	BWH
R484	0757-0388		1	R: fxd metflm 30.1 ohms 1% 1/8w	hp	
R485	0757-0190			R: fxd metflm 20k ohms 1% 1/2w	hp	
R486	0757-0480		1	R: fxd metflm 432k ohms 1% 1/8w	hp	
R487	0757-0273			R: fxd metflm 3.01k ohms 1% 1/8w	hp	
R488				NSR: p/o A403		
R489	0757-0846		1	R: fxd metflm 22.1k ohms 1% 1/2w	hp	
R490	0812-0072		1	R: fxd ww 0.23 ohms 5% 3w	hp	
R491	0757-0421		1	R: fxd metflm 825 ohms 1% 1/8w	hp	
R492	0757-0428		1	R: fxd metflm 1.62k ohms 1% 1/8w	hp	
R493	0757-0844		1	R: fxd metflm 16.2k ohms 1% 1/2w	hp	
R494				NSR: p/o A403		
R495	0698-3555		1	R: fxd metflm 4.437k ohms 1/2% 1/2w	hp	
R496	0698-3554		1	R: fxd metflm 493 ohms 1/2% 1/2w	hp	
R497 - R600				Not assigned		
R601	0757-0401			R: fxd metflm 100 ohms 1% 1/8w	hp	
R602	0757-0481		1	R: fxd metflm 475k ohms 1% 1/8w	hp	
R603	0757-0411		1	R: fxd metflm 332 ohms 1% 1/8w	hp	

Table 6-2. Replaceable Parts (Cont'd)

Ref Desig	hp Part No.	RS	TQ	Description (See Table 6-1.)	Mfr	Mfr Part No.
R604 - R609				Not assigned		
R610	0683-2245		1	R: fxd comp 220k ohms 5% 1/2w	01121	CB 2245
R611	0683-1535		1	R: fxd comp 15k ohms 5% 1/2w	01121	CB 1535
R612	2100-0096		2	R: var comp 1 megohm 30% lin 1/5w	hp	
R613	0757-0280		1	R: fxd metflm 1000 ohms 1% 1/8w	hp	
R614	2100-1722		1	R: var comp 1.5 megohm	hp	
R615	0836-0003		1	R: fxd depc 29 megohms 10% 1w	77764	Type BBF
R616	0757-0344		2	R: fxd metflm 1M ohm 1% 1/4w	hp	
R617	0683-2035		1	R: fxd comp 20k ohms 5% 1/4w	01121	CB 2035
R618	0683-4735		2	R: fxd comp 47k ohms 5% 1/4w	01121	CB 4735
R619	2100-0096			R: var comp 1 megohm 30% lin 1/5w	hp	
R620	0727-0845		3	R: fxd car. flm 1.78M ohms 1% 1/2w	hp	
R621	0727-0845			R: fxd car. flm 1.78M ohms 1% 1/2w	hp	
R622	0683-4735			R: fxd comp 47k ohms 5% 1/4w	01121	CB 4735
R623				Not assigned		
R624	0687-1061		1	R: fxd comp 10M ohms 10% 1/2w	01121	EB 1061
R625	0727-0845			R: fxd car. flm 1.78M ohms 1% 1/2w	hp	
R626	2100-0374		1	R: var comp 5M ohms 30% lin 1/2w	hp	
R627	0698-3553		8	R: fxd car. flm 2.49M 1% 1/2w	hp	
R628	0698-3553			R: fxd car. flm 2.49M 1% 1/2w	hp	
R629	0698-3553			R: fxd car. flm 2.49M 1% 1/2w	hp	
R630	0698-3553			R: fxd car. flm 2.49M 1% 1/2w	hp	
R631	0698-3553			R: fxd car. flm 2.49M 1% 1/2w	hp	
R632	0698-3553			R: fxd car. flm 2.49M 1% 1/2w	hp	
R633	0698-3553			R: fxd car. flm 2.49M 1% 1/2w	hp	
R634	0698-3553			R: fxd car. flm 2.49M 1% 1/2w	hp	
R635 - R640				Not assigned		
R641	2100-0212		1	R: var comp 100k ohms 10% lin 2w	hp	
R642	0757-0454		1	R: fxd metflm 33.2k ohms 1% 1/8w	hp	
R643	2100-0095		1	R: var comp 100k ohms 30% lin 1/5w	hp	
R644	0757-0772			R: fxd metflm 68.1k ohms 1% 1/4w	hp	
R645	0757-0437		1	R: fxd metflm 4.75k ohms 1% 1/8w	hp	
R646 - R649				Not assigned		
R650A/B	2100-0445			R: var comp 2 x 2k ohms 30% lin	hp	
R651	0757-0452		1	R: fxd metflm 27.4k ohms 1% 1/8w	hp	
R652	0757-0465		1	R: fxd metflm 100k ohms 1% 1/8w	hp	
R653	0757-0344			R: fxd metflm 1M ohm 1% 1/4w	hp	
R654	0757-0850			R: fxd metflm 39.2k ohms 1% 1/2w	hp	
R655	0757-0850			R: fxd metflm 39.2k ohms 1% 1/2w	hp	
R656	0757-0388		3	R: fxd metflm 30.1 ohms 1% 1/8w	hp	
R657	0757-0388			R: fxd metflm 30.1 ohms 1% 1/8w	hp	
R701	0757-0388			R: fxd metflm 30.1 ohms 1% 1/8w	hp	
R702	0757-0280		3	R: fxd metflm 1000 ohms 1% 1/8w	hp	
R703	0757-0441		2	R: fxd metflm 8.25k ohms 1% 1/8w	hp	
R704	0757-0441			R: fxd metflm 8.25k ohms 1% 1/8w	hp	
R705	0757-0280			R: fxd metflm 1000 ohms 1% 1/8w	hp	
R706	0757-0280			R: fxd metflm 1000 ohms 1% 1/8w	hp	
R707				Not assigned		

Table 6-2. Replaceable Parts (Cont'd)

Ref Desig	hp Part No.	RS	TQ	Description (See Table 6-1.)	Mfr	Mfr Part No.
R708	0757-0447		1	R: fxd metflm 16.2k ohms 1% 1/8w	hp	
R709	0757-0431		1	R: fxd metflm 2.43k ohms 1% 1/8w	hp	
R710	0757-0288		2	R: fxd metflm 9.09k ohms 1% 1/8w	hp	
R711	0757-0435		1	R: fxd metflm 3.92k ohms 1% 1/8w	hp	
R712	0757-0814		1	R: fxd metflm 511 ohms 1% 1/2w	hp	
R713	0757-0817		1	R: fxd metflm 750 ohms 1% 1/2w	hp	
R714				NSR: p/o A703		
R715 -						
R717				Not assigned		
R718	0757-0466		1	R: fxd metflm 110k ohms 1% 1/8w	hp	
R719	0757-0442		2	R: fxd metflm 10k ohms 1% 1/8w	hp	
R720	0757-0200		1	R: fxd metflm 5.62k ohms 1% 1/8w	hp	
R721	0757-0430		1	R: fxd metflm 2.21k ohms 1% 1/8w	hp	
R722	0757-0288			R: fxd metflm 9.09k ohms 1% 1/8w	hp	
R723	0757-0427		1	R: fxd metflm 1.5k ohms 1% 1/8w	hp	
R724	0757-0839		1	R: fxd metflm 10k ohms 1% 1/2w	hp	
R725				NSR: p/o A703		
R726				NSR: p/o A703		
R727				NSR: p/o A703		
R728	0757-0442			R: fxd metflm 10k ohms 1% 1/8w		
R729	0757-0481		1	R: fxd metflm 475k ohms 1% 1/8w	hp	
R730	0757-0344		1	R: fxd metflm 1 megohm 1% 1/4w	hp	
R731	2100-1721		1	R: var 500k ohms 30% 10 clog taper 1/3w dpst	hp	
R732				Not assigned		
R733	0757-0448		1	R: fxd metflm 18.2k ohms 1% 1/8w	hp	
R734	0757-0124		1	R: fxd metflm 39.2k ohms 1% 1/10w	hp	
R735	0757-0472		1	R: fxd metflm 200k ohms 1% 1/8w	hp	
R736	0757-0444		1	R: fxd metflm 12.1k ohms 1% 1/8w	hp	
R737	0757-0470		1	R: fxd metflm 162k ohms 1/8w	hp	
R738	0757-0481		1	R: fxd metflm 475k ohms 1% 1/8w	hp	
R739	0757-0451		1	R: fxd metflm 24.3k ohms 1% 1/8w	hp	
R740	0757-0457		1	R: fxd metflm 47.5k ohms 1% 1/8w	hp	
R741	0757-0459		1	R: fxd metflm 56.2k ohms 1% 1/8w	hp	
R742	0757-0428		1	R: fxd metflm 1.62k ohms 1% 1/8w	hp	
R743	2100-0898		1	R: var ww 500 ohms 5%	hp	
R744	0757-0417		1	R: fxd metflm 562 ohms 1% 1/8w	hp	
S401	3101-0030		1	S: toggle power	hp	
S402	3101-0033		1	S: slide 115-230v	hp	
S403	3103-0009		1	S: thermal	hp	
S404 -						
S600				Not assigned		
S601	3101-0011		1	S: slide z-axis	hp	
S602	3101-0048		1	S: push button, beam finder	hp	
S603 -						
S700				Not assigned		
S701	3100-1309		1	S: rotary (includes S702)	hp	
S702				NSR: p/o S701		
S703				NSR: p/o R731		
T401	9100-0184		1	T: power	hp	
T402 -						
T600				Not assigned		
T601	00140-86001		1	T: high voltage	hp	
TB601	0360-0104		1	TB: z-axis	hp	

Table 6-2. Replaceable Parts (Cont'd)

Ref Desig	hp Part No.	RS	TQ	Description (See Table 6-1.)	Mfr	Mfr Part No.
V441	1940-0012		2	V: reference 81v	73445	8228Z-Z1000
V442 - V460				Not assigned		
V461	1940-0012			V: reference 81v	73445	8228Z-Z1000
V462 - V600				Not assigned		
V601	1921-0013		1	V: 6CW4	86684	6CW4
V602	1920-0001		4	V: 5642	93332	5642
V603	1920-0001			V: 5642	93332	5642
V604	1920-0001			V: 5642	93332	5642
V605	1920-0001			V: 5642	93332	5642
V606	2140-0008		1	V: neon NE2	24455	NE2
V607 - V609				Not assigned		
V610	2090-0701		1	V: cathode ray	hp	
W401	8120-0078		1	W: power	70903	KH4147
XV601	1200-0086		1	XV: nuvistor 5 pin	71785	133-75-11-028
MISCELLANEOUS						
	120A-20A		1	Bezel: crt	hp	
	175A-83A		1	Retainer: crt shield	hp	
	0360-0362		1	Strip: diode terminal	71785	Type 6-170
	0370-0084		3	Knob: focus, intensity, and persistence	hp	
	0370-0099		1	Knob: mode switch	hp	
	0370-0102		1	Knob: writing rate	hp	
	0380-0046		4	Spacer: 3/8"	00866	OBDS
	0380-0156		4	Spacer: 3/8" long threaded	00866	1940B
	0380-0306		4	Spacer: 9/16"	hp	
	0400-0001		1	Grommet: rubber	73734	1662
	0510-0123		1	Clamp: pilot light	78553	C12008-014-4
	0905-0050		1	Gasket: felt	85471	OBDS
	1200-0037		1	Socket	72825	97097
	1200-0050		10	Pin: crt socket	72825	9553
	1200-0085		1	Cover: crt socket	72825	9109-1
	1200-0088		4	Insulator: anodized alum.	76530	293201
	1200-0184		1	Connector: high voltage	78947	115825
	1400-0087		3	Clip: crt contact	hp	
	1520-0042		4	Mount: vibration	hp	
	2950-0034		2	Nut: 11/16" hex	hp	
	5000-0747		2	Cover: side	hp	
	5040-0400		2	Support: cap	hp	
	5040-0401		4	Support: cap	hp	
	5040-0402		2	Mount: transformer	hp	
	5040-0421		2	Insulator: pot	hp	
	5060-0428		1	Air filter	hp	
	5080-0441		1	Lead: electrical	hp	
	9150-0014		1	Form: coil	08300	SPT MY 198
	00140-00102		1	Deck: vertical	hp	
	00140-00104		1	Gusset: side	hp	

Table 6-2. Replaceable Parts (Cont'd)

Ref Desig	hp Part No.	RS	TQ	Description (See Table 6-1.)	Mfr	Mfr Part No.
	00140-00105		1	Deck: hv	hp	
	00140-00106		1	Deck: main	hp	
	00140-00601		1	Shield: plug-in	hp	
	00140-01201		1	Bracket: latch	hp	
	00140-01202		1	Bracket: diode	hp	
	00140-01206		2	Bracket: fan	hp	
	00140-01208		4	Bracket: panel	hp	
	00140-01209		2	Bracket: gusset	hp	
	00140-01210		2	Bracket: transistor	hp	
	00140-24703		4	Support: panel bracket	hp	
	00140-44701		2	Spacer: cable	hp	
	00140-44702		5	Spacer: cable	hp	
	00140-61605		1	Cable: hv	hp	
	00140-61607		1	Cable: power	hp	
	00141-00101		1	Gusset: center	hp	
	00141-00201		1	Panel: front	hp	
	00141-60601		1	Shield: crt	hp	
	00141-61602		1	Cable: crt	hp	

Table 6-3. Code List of Manufacturers

The following code numbers are from the Federal Supply Code for Manufacturers Cataloging Handbooks H4-1 (Name to Code) and H4-2 (Code to Name) and their latest supplements. The date of revision and the date of the supplements used appear at the bottom of each page. Alphabetical codes have been arbitrarily assigned to suppliers not appearing in the H4 handbooks.

Table with 6 columns: Code No., Manufacturer, Address, Code No., Manufacturer, Address, Code No., Manufacturer, Address. It lists various manufacturers such as U.S.A. Common, McCoy Electronics, Westrex Corp., etc., along with their respective codes and addresses across three pages.

Revised: Nov. 14, 1963
0015-34

F. S. C. Handbook Supplements
H4-1 Dated March 1963
H4-2 Dated March 1962

Table 6-3. Code List of Manufacturers (Cont'd)

Code No.	Manufacturer	Address	Code No.	Manufacturer	Address	Code No.	Manufacturer	Address	Code No.	Manufacturer	Address
82209	Maguire Industries, Inc.	Greenwich, Conn.	87664	Van Waters & Rogers Inc.	Seattle, Wash.	95263	Leecraft Mfg. Co., Inc.	New York, N.Y.	THE FOLLOWING H-P VENDORS HAVE NO NUMBER ASSIGNED IN THE LATEST SUPPLEMENT TO THE FEDERAL SUPPLY CODE FOR MANUFACTURERS HANDBOOK.		
82219	Sylvania Electric Prod., Inc.		88140	Cutler-Hammer, Inc.	Lincoln, Ill.	95264	Lerco Electronics, Inc.	Burbank, Calif.	C0000	JFD Electronics Corp.	Van Nuys, Calif.
82376	Electronic Tube Div.	Emporium, Pa.	88220	Gould-National Batteries, Inc.	St. Paul, Minn.	95265	National Coil Co.	Sheridan, Wyo.	G0000	Tranex Company	Mountain View, Calif.
82385	Astron Co.	East Newark, N.J.	88698	General Mills, Inc.	Buffalo, N.Y.	95275	Vitramon, Inc.	Bridgeport, Conn.	I0000	Western Devices, Inc.	Inglewood, Calif.
82647	Switchcraft, Inc.	Chicago, Ill.	89473	General Electric Distributing Corp.	Schenectady, N.Y.	95348	Gordas Corp.	Bloomfield, N.J.	J0000	Winchester Electronics, Inc.	Santa Monica, Calif.
	Metals and Controls, Inc., Div. of Texas Instruments, Inc., Spencer Prods.	Attleboro, Mass.	89636	Carter Parts Div. of Economy Baler Co.	Chicago, Ill.	95354	Methode Mfg. Co.	Chicago, Ill.			
82866	Research Products Corp.	Madison, Wis.	89665	United Transformer Co.	Chicago, Ill.	95987	Weckesser Co.	Sunnyvale, Calif.			
82877	Rotron Manufacturing Co., Inc.	Woodstock, N.Y.	90179	U.S. Rubber Co., Mechanical Goods Div.	Passaic, N.J.	96067	Huggins Laboratories	Olean, N.Y.			
82993	Vector Electronic Co.	Glendale, Calif.	90970	Bearing Engineering Co.	San Francisco, Calif.	96095	Hi-Q Division of Aerovox	Mt. Carmel, Ill.	0000F	Malco Tool and Die	Los Angeles, Calif.
83053	Western Washer Mfr. Co.	Los Angeles, Calif.	91260	Connor Spring Mfg. Co.	San Francisco, Calif.	96296	Solar Manufacturing Co.	Los Angeles, Calif.	0000M	Western Coil Div. of Automatic Ind., Inc.	Redwood City, Calif.
83058	Carr Fastener Co.	Cambridge, Mass.	91345	Miller Dial & Nameplate Co.	El Monte, Calif.	96330	Carlton Screw Co.	Chicago, Ill.	0000N	Nahm-Bros. Spring Co.	San Leandro, Calif.
83086	New Hampshire Ball Bearing, Inc.	Peterborough, N.H.	91418	Radio Materials Co.	Chicago, Ill.	96341	Microwave Associates, Inc.	Burlington, Mass.	0000O	U.S.A. Common	Any supplier of U.S.
83125	Pyramid Electric Co.	Darlington, S.C.	91506	Augat Brothers, Inc.	Attleboro, Mass.	96501	Excel Transformer Co.	Oakland, Calif.	0000P	Ty-Car Mfg. Co., Inc.	Holliston, Mass.
83148	Electro Cords Co.	Los Angeles, Calif.	91637	Dale Electronics, Inc.	Columbus, Nebr.	97464	Industrial Retaining Ring Co.	Irvington, N.J.	0000T	Texas Instruments, Inc.	Versailles, Ky.
83186	Victory Engineering Corp.	Union, N.J.	91662	Elco Corp.	Philadelphia, Pa.	97539	Automatic and Precision Mfg. Co.	Yonkers, N.Y.			
83298	Bendix Corp., Red Bank Div.	Red Bank, N.J.	91737	Gremar Mfg. Co., Inc.	Wakefield, Mass.	97966	CBS Electronics, Div. of C.B.S., Inc.	Danvers, Mass.	0000U	Tower Mfg. Corp.	New York, N.Y.
83315	Hubbell Corp.	Mundelein, Ill.	91827	K F Development Co.	Redwood City, Calif.	97979	Reon Resistor Corp.	Yonkers, N.Y.	0000V	Webster Electronics Co. Inc.	New York, N.Y.
83330	Smith, Herman H., Inc.	Brooklyn, N.Y.	91929	Minneapolis-Honeywell Regulator Co., Microswitch Div.	Freeport, Ill.	98141	Axel Brothers Inc.	Jamaica, N.Y.	0000Y	Spruce Pine Mica Co.	Spruce Pine, N.C.
83385	Central Screw Co.	Chicago, Ill.	92196	Universal Metal Prod., Inc.	Bassett Puente, Calif.	98159	Rubber Teck, Inc.	Gardena, Calif.	0000Z	Midland Mfg. Co. Inc.	Kansas City, Kans.
83501	Gavitt Wire and Cable Co., Div. of Amerace Corp.	Brookfield, Mass.	92367	Elgeet Optical Co., Inc.	Rochester, N.Y.	98220	Francis L. Mosley	Pasadena, Calif.	000AA	British Radio Electronics Ltd.	Washington, D.C.
83594	Burroughs Corp., Electronic Tube Div.	Plainfield, N.J.	92607	Tinsolite Insulated Wire Co.	Tarrytown, N.Y.	98278	Microdot, Inc.	Pasadena, Calif.	000AB	ETA	England
83740	Eveready Battery	New York, N.Y.	93332	Sylvania Electric Prod. Inc., Semiconductor Div.	Woburn, Mass.	98291	Seaelectro Corp.	Mamaroneck, N.Y.	000AC	Indiana General Corp., Elect. Div.	Indiana
83777	Model Eng. and Mfg., Inc.	Huntington, Ind.	93369	Robbins and Myers, Inc.	New York, N.Y.	98405	Carad Corp.	Redwood City, Calif.	000AD	Curtiss Instrument Inc.	Mt. Kisco, N.Y.
83821	Loyd Struggs Co.	Festus, Mo.	93410	Stevens Mfg. Co., Inc.	Mansfield, Ohio	98731	General Mills	Minneapolis, Minn.	000BB	Precision Instrument Components Co.	Van Nuys, Calif.
84171	Arco Electronics, Inc.	New York, N.Y.	93983	Insuline-Van Norman Ind., Inc. Electronic Division	Manchester, N.H.	98821	North Hills Electric Co.	Mineola, N.Y.			
84396	A. J. Giesener Co., Inc.	San Francisco, Calif.	94144	Raytheon Mfg. Co., Industrial Components Div., Receiving Tube Operation	Quincy, Mass.	98925	Clevite Transistor Prod. Div. of Clevite Corp.	Waltham, Mass.	000CC	Computer Diode Corp.	Lodi, N.J.
84411	Good All Electric Mfg. Co.	Ogallala, Neb.	94145	Raytheon Mfg. Co., Semiconductor Div., California Street Plant	Newton, Mass.	98978	International Electronic Research Corp.	Burbank, Calif.	000EE	A. Williams Manufacturing Co.	San Jose, Calif.
84970	Sarkes Tartzian, Inc.	Bloomington, Ind.	94148	Scientific Radio Products, Inc.	Loveland, Colo.	99109	Columbia Technical Corp.	New York, N.Y.	000GG	Goshen Die Cutting Service	Goshen, Ind.
85454	Boonton Molding Company	Boonton, N.J.	94154	Tung-Sol Electric, Inc.	Newark, N.J.	99313	Varian Associates	Palo Alto, Calif.	000HH	Rubbercraft Corp.	Torrance, Calif.
85471	A. B. Boyd Co.	San Francisco, Calif.	94197	Curtiss-Wright Corp., Electronics Div.	East Paterson, N.J.	99515	Marshall Industries, Electron Products Division	Pasadena, Calif.	000II	Birchler Corporation, Industrial Division	Monterey Park, Calif.
85660	Koiled Kords, Inc.	New Haven, Conn.	94310	Tru Ohm Prod. Div. of Model Engineering and Mfg. Co.	Chicago, Ill.	99707	Control Switch Division, Controls Co. of America	El Segundo, Calif.	000KK	Amatom	New Rochelle, N.Y.
85911	Seamless Rubber Co.	Chicago, Ill.	94682	Worcester Pressed Aluminum Corp.	Worcester, Mass.	99800	Delevan Electronics Corp.	East Aurora, N.Y.	000LL	Avery Label	Monrovia, Calif.
86197	Clifton Precision Products	Clifton Heights, Pa.	95023	Philbrick Researchers, Inc.	Boston, Mass.	99848	Wilco Corporation	Indianapolis, Ind.	000MM	Rubber Eng. & Development	Hayward, Calif.
86579	Precision Rubber Products Corp.	Dayton, Ohio	95236	Allies Products Corp.	Miami, Fla.	99934	Renbrandt, Inc.	Boston, Mass.	000NN	A "N" D Manufacturing Co.	San Jose 27, Calif.
86684	Radio Corp. of America, RCA Electronic Tube Div.	Harrison, N.J.	95238	Continental Connector Corp.	Woodside, N.Y.	99942	Hoffman Semiconductor Div. of Hoffman Electronics Corp.	Evanston, Ill.	000PP	Atomh Electronics	Sun Valley, Calif.
87216	Philito Corporation (Lansdale Division)	Lansdale, Pa.				99957	Technology Instrument Corp of Calif.	Newbury Park, Calif.	000QQ	Cooltron	Oakland, Calif.
87473	Western Fibrous Glass Products Co.	San Francisco, Calif.							000RR	Radio Industries	Des Plaines, Ill.
									000SS	Control of Elgin Watch Co.	Burbank, Calif.
									000WW	California Eastern Lab.	Burlingame, Calif.
									000XX	Methode Electronics, Inc.	Chicago 31, Ill.
									000YY	S.K. Smith Co.	Los Angeles 45, Calif.

00015-34
Revised: Nov. 14, 1963

From: F. S. C. Handbook Supplements
H4-1 Dated March 1963
H4-2 Dated March 1962



CATHODE RAY TUBE WARRANTY

The cathode ray tube (CRT) supplied in your Hewlett-Packard Oscilloscope and replacement CRT's purchased from  are guaranteed by the Hewlett-Packard Company against electrical failure for a period of one year from the date of sale. Broken tubes or tubes with burned phosphor are not included under this guarantee. If the CRT is broken when received, a claim should be made with the responsible carrier.

Your nearest Hewlett-Packard Sales/Service Office (listed at rear of instrument manual) maintains a stock of replacement tubes and will assist in processing the warranty claim.

In order to ensure credit for a CRT under the warranty period, the reverse side of this sheet should be filled out completely and returned with the defective tube to the nearest hp Sales/Service Office. To avoid damage to the tube while in shipment, carefully follow the shipping instructions listed below; credit is not allowed on broken tubes.

SHIPPING INSTRUCTIONS

1. Carefully wrap the tube in 1/4 inch thick cotton batting or other soft padding material.
2. Wrap the above in heavy kraft paper.
3. Pack wrapped tube in a rigid container which is at least 4 inches larger than the tube in each dimension.
4. Surround the tube with at least four inches of packed excelsior or similar shock absorbing material; be sure the packing is tight all around the tube.



CRT WARRANTY CLAIM

CRT WARRANTY CLAIM

FROM: _____ Date _____

NAME _____

COMPANY _____

ADDRESS _____

For additional information, contact:

NAME _____

TITLE _____

COMPANY _____

ADDRESS _____

1. INSTRUMENT a) MODEL _____

b) SERIAL NO. _____

2. CRT a) TYPE (on bulb) _____

b) SERIAL NO. (on CRT base) _____

3. Is defective tube original. YES _____ NO _____

4. Date purchased (if available) _____

5. Describe nature and/or symptoms of trouble. _____

6. Describe operating conditions prior to and at time of failure.
(Please estimate CRT "on-time" since purchase.)

CUT ALONG DOTTED LINE

HEWLETT-PACKARD SALES AND SERVICE OFFICES

in the United States and Canada

ALABAMA

Huntsville, 35802
2003 Byrd Spring Rd. S.W.
(205) 881-4591
TWX: 510-579-2204

ALASKA

Bellevue, Wash. 98004
11656 N.E. 8th Street
(206) 454-3971
TWX: 910-443-2303

ARIZONA

Scottsdale, 85251
3009 No. Scottsdale Rd.
(602) 945-7601
TWX: 602-949-0111

Tucson, 85716
232 So. Tucson Blvd.
(602) 623-2564
TWX: 602-792-2759

CALIFORNIA

North Hollywood, 91604
3939 Lankershim Blvd.
(213) 677-1282 and 766-3811
TWX: 910-499-2170

Sacramento, 95821
2591 Carlsbad Ave.
(916) 482-1463
TWX: 916-444-8683

San Diego, 92106
1055 Shafter Street
(714) 223-8103
TWX: 714-276-4263

Palo Alto, 94303
1101 Embarcadero Rd.
(415) 327-6500
TWX: 910-373-1280

COLORADO

Englewood, 80110
7965 East Prentice
(303) 771-3455
TWX: 303-771-3056

CONNECTICUT

Middletown, 06458
589 Saybrook Rd.
(203) 346-6611
TWX: 710-428-2036

FLORIDA

Miami, 33125
2907 Northwest 7th St.
305 635-6461

Orlando, 32803
621 Commonwealth Ave.
305 425-5541
TWX: 305-275-1234

St. Petersburg, 33708
410-150th Ave. Madeira Beach
813 391-0211
TWX: 813-391-0666

GEORGIA

Atlanta, 30305
3110 Maple Drive, N.E.
(404) 233-1141
TWX: 810-751-3283

HAWAII

North Hollywood, Calif. 91604
3939 Lankershim Blvd.
(213) 877-1282 and 766-3811
TWX: 910-499-2170

ILLINOIS

Skokie, 60078
5500 Howard Street
(312) 677-0400
TWX: 910-223-3613

INDIANA

Indianapolis, 46205
3919 Meadows Dr.
(317) 546-4891
TWX: 317-635-4300

LOUISIANA

New Orleans
(504) 522-4359

MARYLAND

Baltimore, 21207
6660 Security Blvd.
(301) 944-5400

Rockville, 20852
12303 Twinbrook Pkwy
(301) 427-7560
TWX: 710-828-9684

MASSACHUSETTS

Burlington, 01804
Middlesex Turnpike
(617) 272-9000
TWX: 710-332-0382

MICHIGAN

Southfield, 48076
24315 Northwestern Hwy
(313) 353-9100
TWX: 313-357-4425

MINNESOTA

St. Paul, 55114
2459 University Ave.
(612) 646-7881
TWX: 910-563-3734

MISSOURI

Kansas City, 64131
7916 Paseo Street
(816) 444-9494
TWX: 816-556-2423

St. Louis, 63144
2814 South Brentwood Blvd.
314 647-4350
TWX: 314-962-3933

NEW JERSEY

Eatontown
(201) 542-0852

Englewood, 07631
391 Grand Avenue
(201) 567-3933

NEW MEXICO

Albuquerque, 87108
6501 Lomas Blvd., N.E.
(505) 255-5586
TWX: 910-989-1655

Las Cruces, 88001
114 S. Water Street
(505) 526-2486
TWX: 505-524-2671

NEW YORK

New York, 10021
236 East 75th Street
(212) 879-2023
TWX: 710-581-4376

Rochester, 14623
39 Saginaw Drive
(716) 473-9500
TWX: 510-253-5981

Poughkeepsie, 12601
82 Washington Street
(914) 454-7330
TWX: 914-452-7425

Syracuse, 13211
5858 East Molloy Rd.
(315) 454-2486
TWX: 710-541-0482

Endicott, 13764
1219 Campville Rd.
(607) 754-0050
TWX: 510-252-0890

NORTH CAROLINA

High Point, 27262
1923 N. Main Street
(919) 882-6873
TWX: 510-926-1516

OHIO

Cleveland, 44129
5579 Pearl Road
(216) 884-9209
TWX: 216-888-0715

Dayton, 45409
1250 W. Dorothy Lane
(513) 298-0351
TWX: 513-944-0090

OKLAHOMA

Oklahoma City
(405) 235-7062

PENNSYLVANIA

Camp Hill
(717) 737-6791

West Conshohocken, 19428
144 Elizabeth Street
(215) 248-1600 and 828-6200
TWX: 215-828-3847

Monroeville, 15146
2545 Moss Side Blvd.
(412) 271-5227
TWX: 710-797-3650

TEXAS

Dallas, 75209
P.O. Box 7166, 3605 Inwood Rd.
(214) 357-1881 and 332-6667
TWX: 910-861-4081

Houston, 77027
P.O. Box 22813, 4242 Richmond Ave.
(713) 667-2407
TWX: 713-571-1353

UTAH

Salt Lake City, 84115
1482 Major St.
(801) 486-8166
TWX: 801-521-2604

VIRGINIA

Richmond, 23230
2112 Spencer Road
(703) 282-5451
TWX: 710-956-0157

WASHINGTON

Bellevue, 98004
11656 N. E. 8th St.
(206) 454-3971
TWX: 910-443-2303

GOVERNMENT CONTRACTING OFFICES

Middletown, Pa. 17057
Hewlett-Packard
Contract Marketing Division
Olmsted Plaza
(717) 944-7401
TWX: 717-760-4816

West Conshohocken, Pa. 19428
Hewlett-Packard
Contract Marketing Division
144 Elizabeth Street
(215) 753-1811
TWX: 215-820-3847

CANADA

Montreal, Quebec
Hewlett-Packard (Canada) Ltd.
8270 Mayrand Street
(514) 735-2273
TWX: 610-421-3484

Ottawa, Ontario
Hewlett-Packard (Canada) Ltd.
1762 Carling Avenue
(613) 722-4223
TWX: 610-562-1952

Toronto, Ontario
Hewlett-Packard (Canada) Ltd.
1415 Lawrence Avenue West
(416) 249-9196
TWX: 610-492-2382

Vancouver, B.C.
Hewlett-Packard (Canada) Ltd.
2184 W. Broadway
(604) 738-7520
TWX: 610-922-5059

HEWLETT-PACKARD INTERNATIONAL OFFICES

Electronic Instrument Sales and Service

ARGENTINA

Mauricio A. Saurez
Telecomunicaciones
Carlos Calvo 224, Buenos Aires
Tel: 30-6312

AUSTRALIA

Sample Electronics (Vic.) Pty. Ltd.
9-11 Cremorne Street
Richmond E. 1, Victoria
Tel: 42-4757 (3 lines)
Sample Electronics (N.S.W.) Pty. Ltd.
4 Grose Street, Glebe, N.S.W.
Tel: 69-6338 (6 lines)

AUSTRIA

UNILABOR H.m.b.H.
Wissenschaftliche Instrumente
Rummelhardtgasse 6/3
P.O. Box 33, Vienna IX/71
Tel: 42 61 81

BELGIUM

Hewlett-Packard Benelux
20-24 Rue de l'Hopital, Brussels 1
Tel: 11.22.20

BRAZIL

Ciental Importacao e Comercio Ltda.
R. Des Eliseu Guilherme, 62
Sao Paulo 6
Tel: 32-4332

CHILE

Hector Calcagni
Casilla 13942, Santiago
Tel: 6.42.26

COLOMBIA

Instrumentation Henrik A. Langebeck
& Cia. Ltda.
Apartado Aereo 6287
Bogota 1, D.E.
Tel: 45-78-06
Cable: AARIS - Bogota

DENMARK

Tage Olsen A/S
Ronnegade 1, Copenhagen O
Tel: 29.48.00

FINLAND

INTO O/Y
P.O. Box 153
11 Meritullinkatu, Helsinki
Tel: 6.11.33

FRANCE

Hewlett-Packard France
150 Blvd. Massena, Paris 13e
Tel: 707.97.19

GERMANY

Hewlett-Packard VgmbH
Steindamm 35, Hamburg 1
Tel: 24.05.51

Hewlett-Packard VgmbH
Kurfürstenstrasse 95
Frankfurt a. Main
Tel: 52.00.36

Hewlett-Packard VgmbH
Reginfriedstrasse 13
Munich 9
Tel: 49.51.21/2

Hewlett-Packard VgmbH
Technisches Büro
Herrenbergerstrasse 110
703 Boblingen, Württemberg
Tel: 6971

Hewlett-Packard VgmbH
Lietzenburger Strasse 30
1000 Berlin 30
Tel: 24 92 71

GREECE

K. Karayannis
Klaffmonos Square, Athens 124
Tel: 230.301

INDIA

The Scientific Instrument Company, Ltd.
6, Tej Bahadur Sapru Road, Allahabad 1
Tel: 2451

The Scientific Instrument Company, Ltd.
240, Dr. Dadabhai Naoroji Rd., Bombay 1
Tel: 26-2642

The Scientific Instrument Company, Ltd.
11, Esplanade East, Calcutta 1
Tel: 23-4129

The Scientific Instrument Company, Ltd.
30, Mount Road, Madras 2
Tel: 86339

The Scientific Instrument Company, Ltd.
B-7, Ajmeri Gate Extn., New Delhi 1
Tel: 271053

IRAN

Telecom Ltd.
P.O. Box 1812, Tehran
Tel: 43850

ISRAEL

Electronics & Engineering Ltd.
16 Kremenetski St., Tel Aviv
Tel: 35021-2-3

ITALY

Hewlett-Packard Italiana S.p.A.
Viale Lunigiana 46, Milan
Tel: 69.15.84.5/6

Hewlett-Packard Italiana S.p.A.
Palazzo Italia
Piazza Marconi, 25, Roma-Eur
Tel: 59.12.544/5

JAPAN

Yokogawa-Hewlett-Packard Ltd.
2270 Ishikawa-cho
Hachioji, Tokyo
Tel: Hachioji 0426-3-1231 (19 lines)

Yokogawa-Hewlett-Packard Ltd.
No. 3, 6-chome, Aoyama-Kitamachi
Akasaka, Minato-ku, Tokyo
Tel: 403-6511

Yokogawa-Hewlett-Packard Ltd.
No. 8, Umeda, Kita-ku, Osaka
Tel: 313-0091

Yokogawa-Hewlett-Packard Ltd.
No. 4, 3-chome, Himekedoru,
Chigusa-ku, Nagoya
Tel: 751-8545

KOREA

American Trading Company, Korea, Ltd.
112-35 Sokong-Dong, Jung-ku
Seoul P.O. Box 1103, Seoul
Tel: 3-7049, 3-7613

NETHERLANDS

Hewlett-Packard Benelux N.V.
23 Burg Roelstraat, Amsterdam W
Tel: (020) 13.28.98 and 13.54.99

NEW ZEALAND

Sample Electronics (N. Z.) Ltd.
8 Matipo Street
Onehunga S. E. 5, Auckland
Tel: 565-361

NORWAY

Morgenstjerne & Co. A/S
Ingeniørfirma
6 Wessels Gate, Oslo
Tel: 20 16 35

PANAMA

Electronico Balboa, S.A.
P.O. Box 4929
Panama City 5, Panama
Tel: 3-0833

PERU

Fernando Ezeta B.
Casilla 3061
Lima
Tel: 78745

PORTUGAL

TELECTRA
Rua Rodrigo da Fonseca 103
P.O. Box 2531, Lisbon 1
Tel: 68 60 72 and 68 60 73 and 68 60 74

PUERTO RICO & VIRGIN ISLANDS

San Juan Electronics, Inc.
150 Ponce de Leon, Stop 3
P.O. Box 5167
Pta. de Tierra Sta., San Juan 00906
Tel: 725-3342, 724-4406

SPAIN

ATAIO, Ingenieros
Enrique Larreta 12, Madrid 6
Tel: 235.43.44 and 235.43.45

SOUTH AFRICA

F. H. Flanter & Co (Pty.) Ltd.
Rosella House
Britencingle Street, Cape Town
Tel: 3-3817

SWEDEN

H-P Instrument AB
Centralvagen 28, Solna, Centrum
Tel: 83.08.30
H-P Instrument AB
Idunagatan 28A
Goteborg
Tel: 27 68 00 and 27 68 01

SWITZERLAND

Max Paul Frey
Wankdorffeldstrasse 66, Berne
Tel: (031) 42.00.78

TAIWAN (FORMOSA)

Hwa Sheng Electronic Co., Ltd.
21 Nanking West Road, Taipei
Tel: 4 6076, 4 5936

TURKEY

TELEKOM Engineering Bureau
P.O. Box 376—Galata, Istanbul
Tel: 49 40 40

UNITED KINGDOM

Hewlett-Packard Ltd.
Dallas Rd, Bedford, England
Tel: Bedford 68052

VENEZUELA

Citec, C. A.
Edif. Arisan-Of #4
Avenida Francisco de Miranda-Chacarito
Apartado del Este 10.837, Caracas
Tel: 71 88 05

YUGOSLAVIA

Belram S.A.
83 Avenue des Mimosas
Brussels 15, Belgium
Tel: 35 29 58

For Sales and Service Assistance in Areas Not Listed Contact:

IN EUROPE

Hewlett-Packard, S. A.
54 Route des Acacias
Geneva, Switzerland
Telephone: (022) 42.81.50
Telex: 2.24.86
Cable: HEWPACKSA

IN LATIN AMERICA

Hewlett-Packard Inter-Americas
1501 Page Mill Road
Palo Alto, California 94304, U.S.A.
Telephone: (415) 326-7000
TWX: 910-373-1267
Telex: 033811 Cable: HEWPACK

ELSEWHERE

Hewlett-Packard
Overseas Sales Department
1501 Page Mill Road
Palo Alto, California 94304, U.S.A.
Telephone: 415 326-7000
TWX: 910 373 1267
Telex: 033811 Cable HEWPACK